

standard grade 1

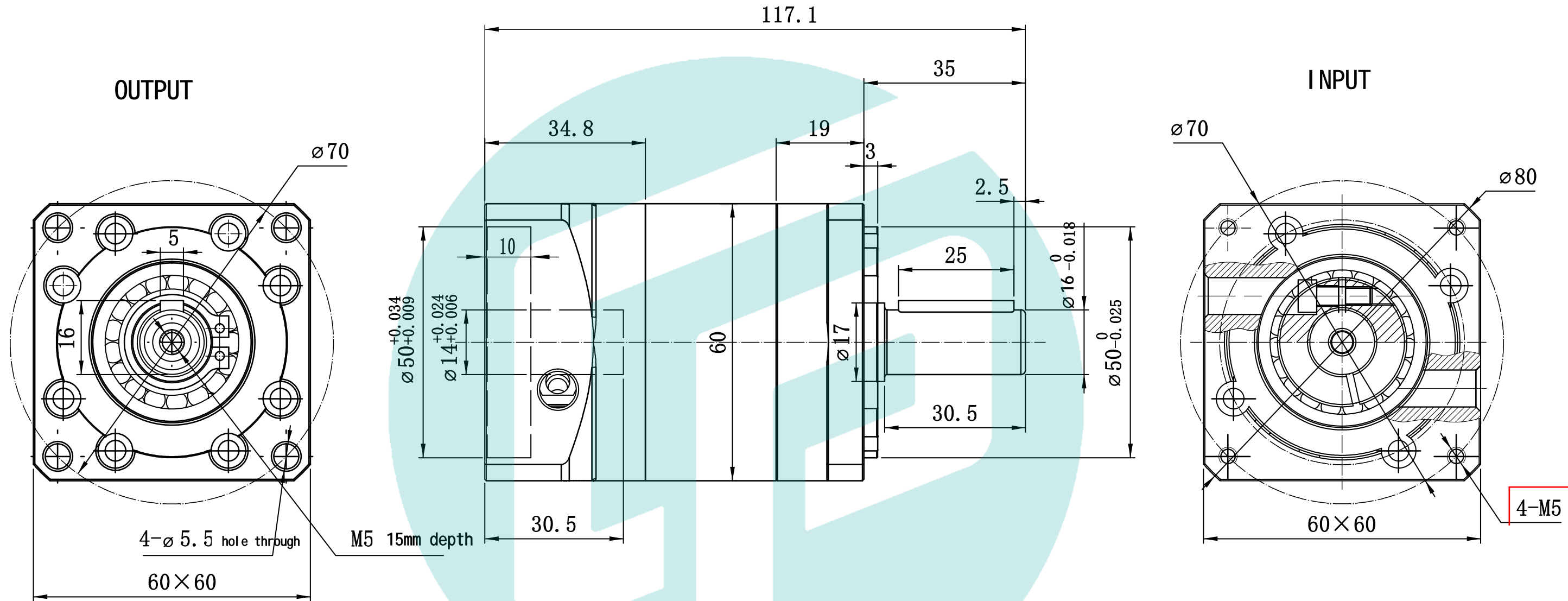

speed ratio	1:3	1:4	1:5	1:7	1:10
rated output torque(N.M)	12	16	16	15	12
inertia moment(kg.cm <sup>2</sup> )	0.135	0.093	0.078	0.065	0.054
noise (L=100cm)	≤68dB				

scram torque(N.M)	2 times output torque	backlash	≤10
gear grade	1	rated input speed(rpm)	3000
allowable radial load(N)	450	maximal input speed(rpm)	4500
allowable axial load(N)	340	protection lever IP	IP54
transmission efficiency	≥96%		

DRAWING				MODEL	60SPF series
				60SPF GRADE 1	
S	A	B			