

<https://shop.cncparts.ir>

*User's Manual  
For DMA860H*



نشانی: تهران - خیابان سعدی جنوبی - چهارراه اکباتان ناظم الاطبا شمالی - پلاک ۱۶۷

تلفن : ۳۶۶۱۹۳۹۰ - ۳۶۶۱۹۵۱۰ - ۳۳۹۵۹۷۵۶ - ۳۳۹۵۹۷۵۶ - ۳۳۵۳۲۱۹۴ - ۳۳۹۵۹۳۲۶ - ۳۳۵۳۲۶۰۲

<https://shop.cncparts.ir>

**CNC PARTS**

## Contents

1 Introduction, Features and Applications.....	3	12. Frequently Asked Questions .....	9
1.1 Introduction.....	3	Problem Symptoms and Possible Causes.....	9
1.2 Features.....	3	13 Warranty .....	10
1.3 Applications.....	3	Exclusions.....	10
2 Specifications.....	3	Obtaining Warranty Service.....	10
2.1 Electrical Specifications ( $T_j = 25^{\circ}\text{C}/77^{\circ}\text{F}$ ) .....	3	Warranty Limitations.....	10
2.2 Mechanical Specifications (unit: mm [inch]) .....	3	Contact us .....	11
2.3 Elimination of Heat.....	3		
2.4 Operating Environment and other Specifications.....	4		
3. Pin Assignment and Description.....	4		
3.1 Connector P1 Configurations.....	4		
3.2 Selecting Active Pulse Edge and Control Signal Mode.....	4		
3.3 Connector P2 Configurations.....	4		
4. Control Signal Connector (P1) Interface.....	4		
5. Connecting the Motor.....	5		
5.1 Connections to 4-lead Motors.....	5		
5.2 Connections to 6-lead Motors.....	5		
5.3 Half Coil Configurations.....	5		
5.4 Full Coil Configurations.....	5		
5.5 Connections to 8-lead Motors.....	6		
6. Power Supply Selection.....	6		
6.1 Regulated or Unregulated Power Supply .....	6		
6.2 Multiple Drives.....	6		
6.3 Selecting Supply Voltage .....	7		
7. Selecting Microstep Resolution and Drive Output Current.....	7		
7.1 Microstep Resolution Selection.....	7		
7.2 Current Settings.....	7		
8. Wiring Notes.....	8		
9. Typical Connection.....	8		
10. Sequence Chart of Control Signals.....	8		
11. Protection Functions .....	9		

## 1 Introduction, Features and Applications

### 1.1 Introduction

The DMA860H is a versatility fully digital stepping Drive based on a DSP with advanced control algorithm. The DMA860H is the latest generation of digital stepper motor controls. It brings a unique level of system smoothness, providing optimum torque and nulls mid-range instability. Motor self-test and parameter auto-tuning technology offers optimum responses with different motors and easy-to-use. The motors can run with extra small noise, low heating, smooth movement. Its unique features make the DMA860H an ideal solution for applications that require low-speed smooth movement.

### 1.2 Features

- Anti-Resonance, provides optimum torque and nulls mid-range instability
- Motor self-test and parameter auto-tuning technology, offers optimum responses with different motors
- Multi-Stepping allows a low resolution step input to produce a higher microstep output for smooth system performance
- Microstep resolutions programmable, from full-step to 102,400 steps/rev
- Supply voltage up to 80VAC/+80VDC
- Output current programmable, from 0.5A to 7.2A
- Pulse input frequency up to 200 KHz
- TTL compatible and optically isolated input
- Automatic idle-current reduction
- Suitable for 2-phase and 4-phase motors
- Support PUL/DIR and CW/CCW modes
- Over-voltage, over-current, phase-error protections

### 1.3 Applications

Suitable for a wide range of stepping motors, from NEMA frame size 17 to 34. It can be used in various kinds of machines, such as laser cuttings, laser markers, high precision X-Y tables, labeling machines, and so on. Its unique features make the DMA860H an ideal solution for applications that require both low-speed smoothness and high speed performances.

## 2 Specifications

### 2.1 Electrical Specifications (Tj = 25°C/77°F)

Parameters	DMA860H			Unit
	Min	Typical	Max	
Output current[PK]	0.5	-	7.2(6.0 RMS)	A
Supply voltage	24	48	80	Vac
Pulse Voltage	4	5	28	Vdc
Logic signal current	7	10	16	mA
Pulse input frequency	0	-	200	KHz
Isolation resistance	100	-	-	MΩ

### 2.2 Mechanical Specifications (unit: mm [inch])

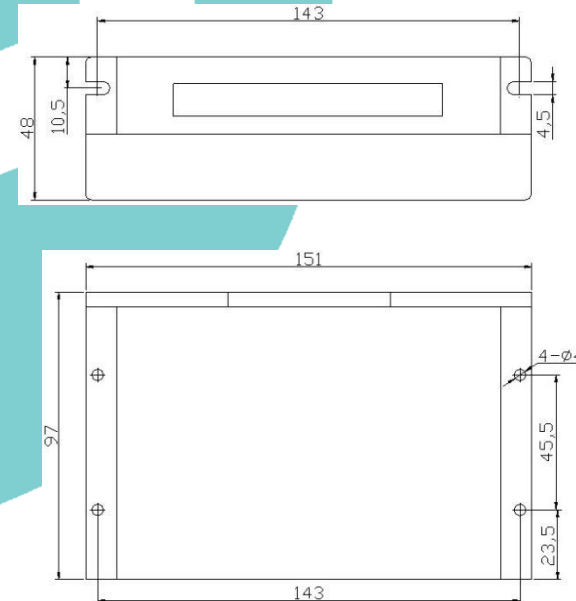

Figure 1: Mechanical specifications

### 2.3 Elimination of Heat

Drive's reliable working temperature should be <70°C (158°F), and motor working temperature

should be  $<80^{\circ}\text{C}$  ( $176^{\circ}\text{F}$ );

It is recommended to use automatic idle-current mode, namely current automatically reduce to 60% when motor stops, so as to reduce Drive heating and motor heating;

The Drive must be mounted vertically to maximize heat sink area as shown in the following picture. Use forced cooling method to cool the system if necessary.

### 2.4 Operating Environment and other Specifications

Cooling	Natural Cooling or Forced cooling	
Operating Environment	Environment	Avoid dust, oil fog and corrosive gases
	Ambient Temperature	$0^{\circ}\text{C} - 50^{\circ}\text{C}$ ( $32^{\circ}\text{F} - 122^{\circ}\text{F}$ )
	Humidity	40%RH - 90%RH
	Operating Temperature	$70^{\circ}\text{C}$ ( $158^{\circ}\text{F}$ ) Max
Storage Temperature	$-20^{\circ}\text{C} - 65^{\circ}\text{C}$ ( $-4^{\circ}\text{F} - 149^{\circ}\text{F}$ )	
Weight	Approx. 280g (10 oz)	

### 3. Pin Assignment and Description

The DMA860H has two connectors, connector P1 for control signals connections, and connector P2 for power and motor connections. The following tables are brief descriptions of the two connectors.

More detailed descriptions of the pins and related issues are presented in section 4, 5, 9.

#### 3.1 Connector P1 Configurations

Pin Function	Details
PUL+	<b>Pulse signal:</b> In Pulse+direction mode, this input represents pulse signal, active at each rising or falling edge, In CW/CCW mode, this input represents clockwise (CW) pulse, active both at each high level and low level. 4-28V for PUL-HIGH,

PUL-	0-0.5V for PUL-LOW. For reliable response, pulse width should be longer than $2.5\mu\text{s}$ for 200K MAX input frequency or $1\mu\text{s}$ for 500K MAX input frequency.
DIR+	<b>Dir signal:</b> In Pulse+direction mode, this signal has low/high voltage levels representing two directions of motor rotation; in CW/CCW mode (software configurable), this signal is counter-clock (CCW) pulse, active both at high level and low level (software configurable). For reliable motion response, DIR signal should be ahead of PUL signal by $2.5\mu\text{s}$ at least. 4-28V when DIR-HIGH, 0-0.5V when DIR-LOW. Please note that rotation direction is also related to motor-Drive wiring match. Exchanging the connection of two wires for a coil to the Drive will reverse motion direction.
DIR-	
ENA+	<b>Enable signal:</b> This signal is used for enabling/disabling the Drive. High level (NPN control signal, PNP and Differential control signals are on the contrary, namely Low level for enabling.) for enabling the Drive and low level for disabling the Drive. Usually left UNCONNECTED (ENABLED).
ENA-	

#### 3.2 Selecting Active Pulse Edge and Control Signal Mode

The DMA860H supports PUL/DIR and CW/CCW modes and pulse actives at rising or falling edge. See more information about these settings in Section 13. Default setting is PUL/DIR mode and rising edge active (NPN, and PNP control signal is on the contrary).

#### 3.3 Connector P2 Configurations

Pin Function	Details
AC	Power supply, 24-80 Vac or 24-110Vdc, Including voltage fluctuation and EMF voltage.
AC	Power supply, 24-80 Vac or 24-80Vdc, Including voltage fluctuation and EMF voltage.
A+, A-	Motor Phase A
B+, B-	Motor Phase B

### 4. Control Signal Connector (P1) Interface

The DMA860H can accept differential and single-ended inputs (including open-collector and

output). The DMA860H has 3 isolated optocoupler inputs which are located on connector P1 to accept line Drive control signals. These inputs are isolated to minimize or eliminate electrical noises coupled onto the Drive control signals. Recommend use line Drive control signals to increase noise immunity of the Drive in interference environments. In the following figures, connections to open-collector and PNP signals are illustrated.

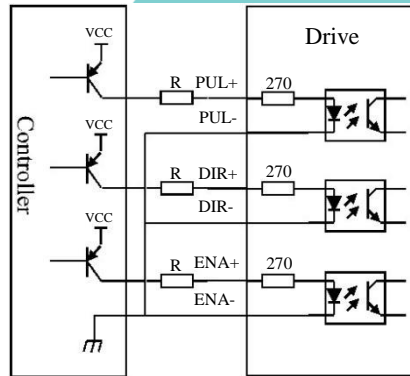
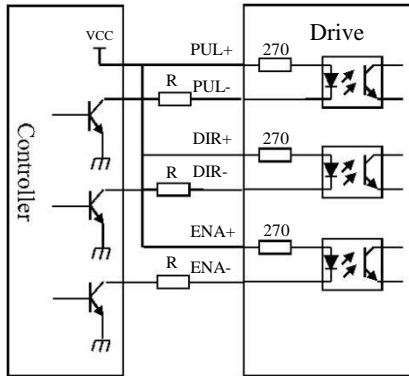

Figure 2 Connections to open-collector signal

Figure 3 Connections to PNP

Attention: If  $VCC=4 \sim 28Vdc$ , R short circuit;

## 5. Connecting the Motor

The DMA860H can Drive any 2-phase and 4-phase hybrid stepping motors.

### 5.1 Connections to 4-lead Motors

4 lead motors are the least flexible but easiest to wire. Speed and torque will depend on winding inductance. In setting the Drive output current, multiply the specified phase current by 1.4 to determine the peak output current.

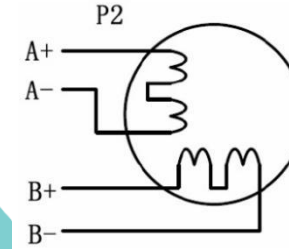

Figure 4: 4-lead Motor Connections

### 5.2 Connections to 6-lead Motors

Like 8 lead stepping motors, 6 lead motors have two configurations available for high speed or high torque operation. The higher speed configuration, or half coil, is so described because it uses one half of the motor's inductor windings. The higher torque configuration, or full coil, uses the full windings of the phases.

### 5.3 Half Coil Configurations

As previously stated, the half coil configuration uses 50% of the motor phase windings. This gives lower inductance, hence, lower torque output. Like the parallel connection of 8 lead motor, the torque output will be more stable at higher speeds. This configuration is also referred to as half chopper. In setting the Drive output current multiply the specified per phase (or unipolar) current rating by 1.4 to determine the peak output current.

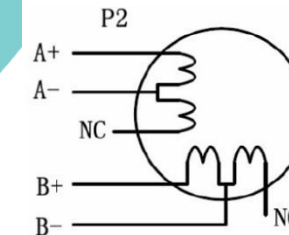

Figure 5: 6-lead motor half coil (higher speed) connections

### 5.4 Full Coil Configurations

The full coil configuration on a six lead motor should be used in applications where higher torque at lower speeds is desired. This configuration is also referred to as full copper. In full coil mode, the motors should be run at only 70% of their rated current to prevent over heating.

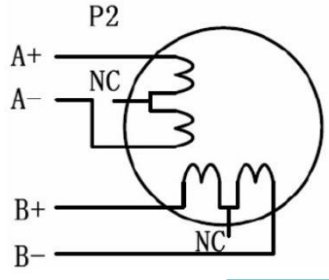

Figure 6: 6-lead motor full coil (higher torque) connections

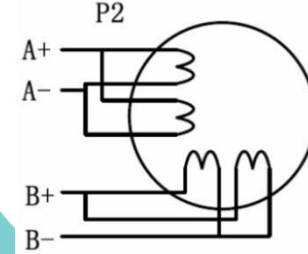

Figure 8: 8-lead motor parallel connections

### 5.5 Connections to 8-lead Motors

8 lead motors offer a high degree of flexibility to the system designer in that they may be connected in series or parallel, thus satisfying a wide range of applications.

#### Series Connections

A series motor configuration would typically be used in applications where a higher torque at lower speeds is required. Because this configuration has the most inductance, the performance will start to degrade at higher speeds. In series mode, the motors should also be run at only 70% of their rated current to prevent over heating.

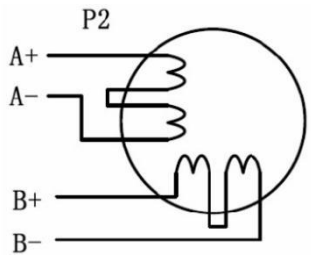

Figure 7: 8-lead motor series connections

#### Parallel Connections

An 8 lead motor in a parallel configuration offers a more stable, but lower torque at lower speeds. But because of the lower inductance, there will be higher torque at higher speeds. Multiply the per phase (or unipolar) current rating by 1.96, or the bipolar current rating by 1.4, to determine the peak output current.

**NEVER** disconnect or connect the motor while the power source is energized.

## 6. Power Supply Selection

The DMA860H can match medium and small size stepping motors (from NEMA frame size 17 to 34). To achieve good driving performances, it is important to select supply voltage and output current properly. Generally speaking, supply voltage determines the high speed performance of the motor, while output current determines the output torque of the motor (particularly at lower speed). Higher supply voltage will allow higher motor speed to be achieved, at the price of more noise and heating. If the motion speed requirement is low, it's better to use lower supply voltage to decrease noise, heating and improve reliability.

### 6.1 Regulated or Unregulated Power Supply

Both regulated and unregulated power supplies can be used to supply the Drive. However, unregulated power supplies are preferred due to their ability to withstand current surge. If regulated power supplies (such as most switching supplies.) are indeed used, it is important to have large current output rating to avoid problems like current clamp, for example using 4A supply for 3A motor-Drive operation. On the other hand, if unregulated supply is used, one may use a power supply of lower current rating than that of motor (typically 50%~70% of motor current). The reason is that the Drive draws current from the power supply capacitor of the unregulated supply only during the ON duration of the PWM cycle, but not during the OFF duration. Therefore, the average current withdrawn from power supply is considerably less than motor current. For example, two 3A motors can be well supplied by one power supply of 4A rating.

### 6.2 Multiple Drives

It is recommended to have multiple Drives to share one power supply to reduce cost, if the

supply has enough capacity. To avoid cross interference, **DO NOT** daisy-chain the power supply input pins of the Drives. Instead, please connect them to power supply separately.

### 6.3 Selecting Supply Voltage

The power MOSFETS inside the DMA860H can actually operate within 24~ 75Vac, including power input fluctuation and back EMF voltage generated by motor coils during motor shaft deceleration. Higher supply voltage can increase motor torque at higher speeds, thus helpful for avoiding losing steps. However, higher voltage may cause bigger motor vibration at lower speed, and it may also cause over-voltage protection or even Drive damage. Therefore, it is suggested to choose only sufficiently high supply voltage for intended applications, and it is suggested to use power supplies with theoretical output voltage of 24~ 80Vac, leaving room for power fluctuation and back-EMF.

## 7. Selecting Microstep Resolution and Drive Output Current

Microstep resolutions and output current are programmable, the former can be set from full-step to 102,400 steps/rev and the latter can be set from 0.5A to 7.2A. See more information about **Microstep and Output Current Setting** in Section 13. However, when it's not in software configured mode, this Drive uses an 8-bit DIP switch to set microstep resolution, and motor operating current, as shown below:

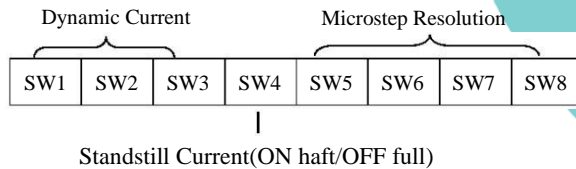

### 7.1 Microstep Resolution Selection

When it's not in software configured mode, microstep resolution is set by SW5, 6, 7, 8 of the DIP switch as shown in the following table:

Microstep	Steps/rev.(for 1.8°motor)	SW5	SW6	SW7	SW8
2	400	ON	ON	ON	ON
4	800	OFF	ON	ON	ON
8	1600	ON	OFF	ON	ON

16	3200	OFF	OFF	ON	ON
32	6400	ON	ON	OFF	ON
64	12800	OFF	ON	OFF	ON
128	25600	ON	OFF	OFF	ON
256	51200	OFF	OFF	OFF	ON
5	1000	ON	ON	ON	OFF
10	2000	OFF	ON	ON	OFF
20	4000	ON	OFF	ON	OFF
25	5000	OFF	OFF	ON	OFF
40	8000	ON	ON	OFF	OFF
50	10000	OFF	ON	OFF	OFF
100	20000	ON	OFF	OFF	OFF
200	40000	OFF	ON	OFF	OFF

### 7.2 Current Settings

For a given motor, higher Drive current will make the motor to output more torque, but at the same time causes more heating in the motor and Drive. Therefore, output current is generally set to be such that the motor will not overheat for long time operation. Since parallel and serial connections of motor coils will significantly change resulting inductance and resistance, it is therefore important to set Drive output current depending on motor phase current, motor leads and connection methods. Phase current rating supplied by motor manufacturer is important in selecting Drive current, however the selection also depends on leads and connections.

When it's not in software configured mode, the first three bits (SW1, 2, 3) of the DIP switch are used to set the dynamic current. Select a setting closest to your motor's required current.

#### Dynamic current setting

Peak Current	RMS Current	SW1	SW2	SW3
<b>Default/Software configured</b>				
3.08A	2.57A	ON	ON	ON
3.77A	3.14A	OFF	ON	ON
4.45A	3.71A	ON	OFF	ON
5.14A	4.28A	OFF	OFF	ON
		ON	ON	OFF

5.83A	4.86A	OFF	ON	OFF
6.52A	5.43A	ON	OFF	OFF
7.20A	6.00A	OFF	OFF	OFF

**Notes:** Due to motor inductance, the actual current in the coil may be smaller than the dynamic current setting, particularly under high speed condition.

### Standstill current setting

SW4 is used for this purpose. OFF meaning that the standstill current is set to be half of the selected dynamic current, and ON meaning that standstill current is set to be the same as the selected dynamic current.

The current automatically reduced to 60% of the selected dynamic current one second after the last pulse. Theoretically, this will reduce motor heating to 36% (due to  $P=I^2 \cdot R$ ) of the original value. If the application needs a different standstill current, please contact Fulling.

## 8. Wiring Notes

In order to improve anti-interference performance of the Drive, it is recommended to use twisted pair shield cable.

To prevent noise incurred in PUL/DIR signal, pulse/direction signal wires and motor wires should not be tied up together. It is better to separate them by at least 10 cm, otherwise the disturbing signals generated by motor will easily disturb pulse direction signals, causing motor position error, system instability and other failures.

If a power supply serves several Drives, separately connecting the Drives is recommended instead of daisy-chaining.

It is prohibited to pull and plug connector P2 while the Drive is powered ON, because there is high current flowing through motor coils (even when motor is at standstill). Pulling or plugging connector P2 with power on will cause extremely high back-EMF voltage surge, which may damage the Drive.

## 9. Typical Connection

A complete stepping system should include stepping motor, stepping Drive, power supply and

controller (pulse generator). A typical connection is shown as figure 9.

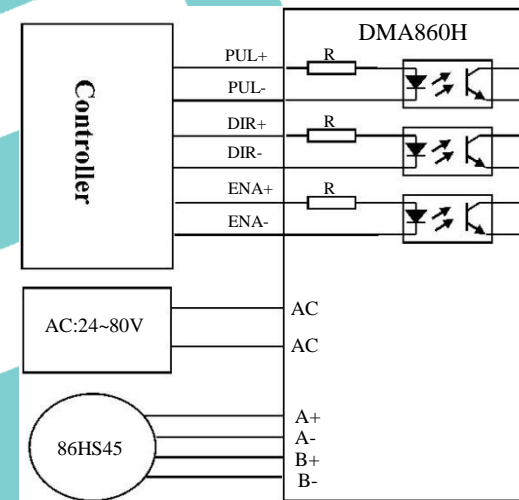
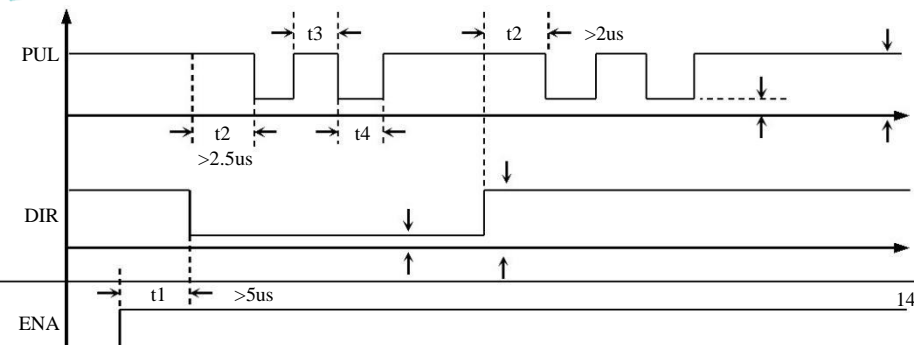

Figure 9 DMA860H Typical connection

## 10. Sequence Chart of Control Signals

In order to avoid some fault operations and deviations, PUL, DIR and ENA should abide by some rules, shown as following diagram:



**Remark:**

- a) t1: ENA must be ahead of DIR by at least 5s. Usually, ENA+ and ENA- are NC (not connected). See “Connector P1 Configurations” for more information.
- b) t2: DIR must be ahead of PUL active edge by 2.5s to ensure correct direction;
- c) t3: Pulse width not less than 2s;
- d) t4: Low level width not less than 2s.

**11. Protection Functions**

To improve reliability, the Drive incorporates some built-in protection functions. The DMA860H uses one RED LED to indicate what protection has been activated. The periodic time of RED is 3s (seconds), and how many times the RED turns on indicates what protection has been activated. Because only one protection can be displayed by RED LED, so the Drive will decide what error to display according to their priorities. See the following Protection Indications table for displaying priorities.

**Over-current Protection**

Over-current protection will be activated when continuous current exceeds 22A or in case of short circuit between motor coils or between motor coil and ground, and RED LED will turn on once within each periodic time (3 s).

**Over-voltage Protection**

When power supply voltage exceeds 90±2VAC, protection will be activated and RED LED will turn on twice within each periodic time (3 s).

**Phase Error Protection**

Motor power lines wrong & not connected will activate this protection. RED LED will turn on four times within each periodic time (3 s).

**Attention:** When above protections are active, the motor shaft will be free or the LED will turn red. Reset the Drive by repowering it to make it function properly after removing above problems.

Since there is no protection against power leads ( + , - ) reversal, it is critical to make sure that power supply leads correctly connected to Drive. Otherwise, the Drive will be damaged instantly.

**Protection Indications**

Priority	Time(s) of ON	Sequence wave of RED LED	Description
1st	1	⎓	Over-current protection
2nd	2	⎓ ⎓	Over-voltage protection
3rd	4	⎓ ⎓ ⎓ ⎓	NC

**12. Frequently Asked Questions**

In the event that your Drive doesn't operate properly, the first step is to identify whether the problem is electrical or mechanical in nature. The next step is to isolate the system component that is causing the problem. As part of this process you may have to disconnect the individual components that make up your system and verify that they operate independently. It is important to document each step in the troubleshooting process. You may need this documentation to refer back to at a later date, and these details will greatly assist our Technical Support staff in determining the problem should you need assistance.

Many of the problems that affect motion control systems can be traced to electrical noise, controller software errors, or mistake in wiring.

**Problem Symptoms and Possible Causes**

Symptoms	Possible Problems
Motor is not rotating	No power
	Microstep resolution setting is wrong
	DIP switch current setting is wrong
	Fault condition exists

	<b>The Drive is disabled</b>
<b>Motor rotates in the wrong direction</b>	<b>Motor phases may be connected in reverse</b>
<b>The Drive in fault</b>	<b>DIP switch current setting is wrong</b> <b>Something wrong with motor coil</b>
<b>Erratic motor motion</b>	<b>Control signal is too weak</b>
	<b>Control signal is interfered</b>
	<b>Wrong motor connection</b>
<b>Motor stalls during acceleration</b>	<b>Something wrong with motor coil</b>
	<b>Current setting is too small, losing steps</b>
	<b>Current setting is too small</b>
	<b>Motor is undersized for the application</b>
<b>Excessive motor and Drive heating</b>	<b>Power supply voltage too low</b>
	<b>Acceleration is set too high</b>
	<b>Inadequate heat sinking / cooling</b>
	<b>Automatic current reduction function not being utilized</b>
	<b>Current is set too high</b>

### **13 Warranty**

Shenzhen ECON Technology Co., Ltd. warrants its products against defects in materials and workmanship for a period of 12 months from shipment out of factory. During the warranty period, ECON technology will either, at its option, repair or replace products which proved to be defective.

#### **Exclusions**

The above warranty does not extend to any product damaged by reasons of improper or inadequate handlings by customer, improper or inadequate customer wirings, unauthorized modification or misuse, or operation beyond the electrical specifications of the product and/or operation beyond environmental specifications for the product.

#### **Obtaining Warranty Service**

To obtain warranty service, a returned material authorization number (RMA) must be obtained from customer service at e-mail: [technical01@hybridservo.com](mailto:technical01@hybridservo.com) before returning product for service. Customer shall prepay shipping charges for products returned to ECON technology for warranty service, and ECON technology shall pay for return of products to customer.

#### **Warranty Limitations**

ECON technology makes no other warranty, either expressed or implied, with respect to the product. ECON technology specifically disclaims the implied warranties of merchantability and fitness for a particular purpose. Some jurisdictions do not allow limitations on how long and implied warranty lasts, so the above limitation or exclusion may not apply to you. However, any implied warranty of merchantability or fitness is limited to the 12-month duration of this written warranty.



**CNC PARTS**