

## ES750 High Voltage Pulse Servo Driver User Manual V.1.0

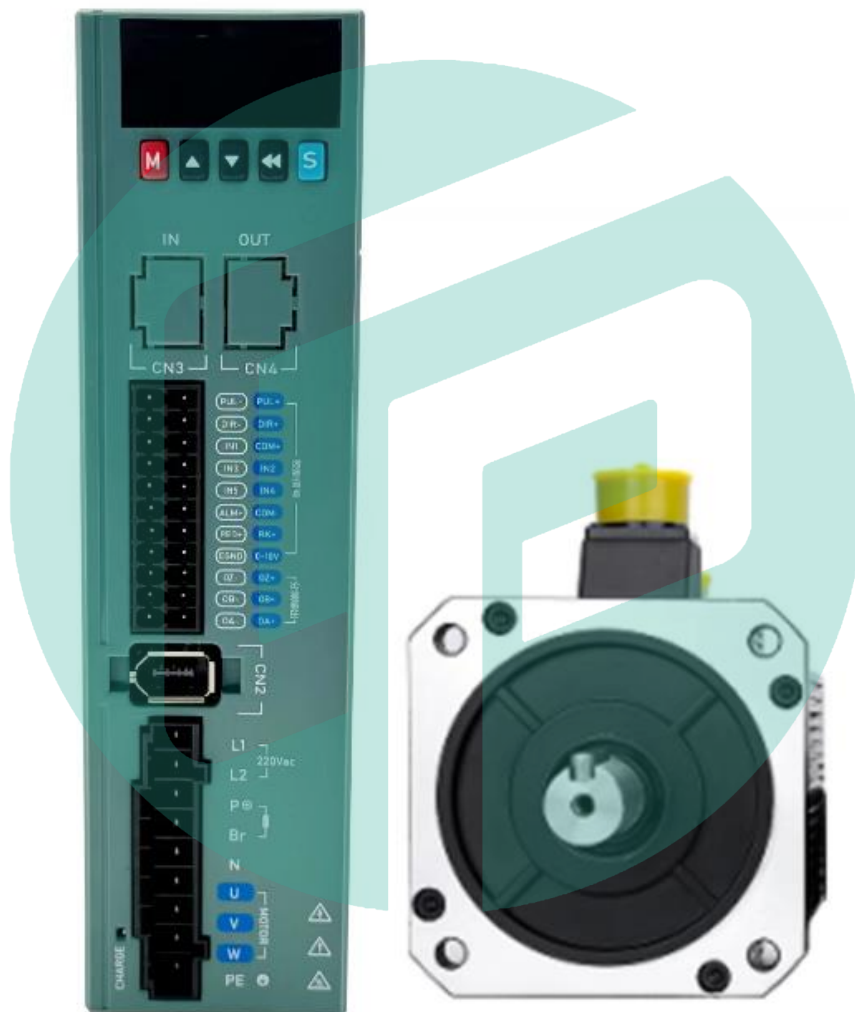

# CNC PARTS

## Foreword

### Product Overview

First of all, thank you for purchasing and using our high-voltage pulse servo drive. Pulse type series is our company is different from the digital display type of Ether CAT bus driver products, the whole series of products on the basis of the previous products added built-in relays, direct control of motor brakes, terminal blocks are simple and easy to use, in engraving, laser, CNC equipment, sewing, photovoltaic, textile, civil, robots, lithium battery equipment, 3C electronics, dispensing and other industries have been widely used.

This manual only describes the specifications and applications of high-voltage pulse servo drives. If you have any doubts about the use of the product, please consult our technician or distributor for assistance.

Thank you again for buying the high-voltage servo drive product of Shenzhen ECON Technology Co., Ltd., this manual provides the required knowledge and precautions for using this product.

**Improper operation may cause accidents, please be sure to read this manual carefully before using this product**

We will not assume any responsibility for any changes to the product by the user, and the warranty and warranty of the product will be invalid.

As you read this manual, pay special attention to the following tips:

#### Warning



- 1. Only technicians can debug, install and repair this product;**
- 2. Make sure that the line connection is correct before the power test;**
- 3. Incorrect voltage or power supply polarity may damage the drive or cause other accidents**

## Safety Matters

### Overall Cautions



**Danger**

- Do not remove the housing, cables, connectors and optional equipment when the driver is energized.
- Disconnect the power supply for at least 5 minutes to confirm that the power indicator is off, and then perform wiring and inspection operations. Even if the power supply is disconnected, there may still be residual voltage inside the driver. Therefore, do not touch the power terminals while the power indicator is on.



**Warning**

- 1. Please use the power supply specifications (phase, voltage, frequency, AC/DC) that match the product.
- 2. Be sure to connect the grounding terminal of the driver (mounting surface) and the motor with the grounding electrode.
- 3. Do not damage or drag the cable hard, do not overexert the cable, do not hang heavy objects on the cable, or be caught by the cabinet door.
- 4. Do not disassemble, repair or modify the product without permission.
- 5. When starting operation after being connected to the machine, make sure that the device can be stopped in an emergency state at any time.
- 6. Do not touch the inside of the driver.



**Attention**

1. When the power is turned on or when the power supply is just cut off, the heat sink and motor of the driver may be in a high temperature state. Take safety measures, such as installing an outer cover, to prevent accidental contact between hands and parts (cables, etc.).
2. Please use double-insulated or reinforced insulated equipment to control the power supply.
3. Do not use the product in the vicinity of places where water will be splashed, corrosive environments, flammable gas atmospheres, and combustibles.
4. Do not use drivers and motors that are damaged or have missing parts.
5. Please set up an emergency stop circuit externally to ensure that the power supply can be cut off and the operation can be stopped immediately in the event of an abnormality.
6. When using the power supply in a bad condition, set up a protective device (AC reactor, etc.) to ensure that the input power supply is supplied within the specified voltage fluctuation range.
7. Use noise filters to reduce the effects of electromagnetic interference.
8. Please use the combination of the driver and the motor according to the specified.

### Storage and Transport Attention



**Attention**

1. Please follow the instructions on the outer packaging for storage, and do not apply excessive load to the product.
2. Please place this product in the following environment:
  - places without direct sunlight.
  - places where the ambient temperature does not exceed the product specifications.
  - places where the relative humidity does not exceed the product specifications and there is no condensation.
  - place free of corrosive or flammable gases.
  - places where there is little dust, dust, salt and metal powder.
  - place where there is no splash of water, oil, medicine, etc.
  - places where vibration or shock does not exceed the specifications of the product.There are no devices that generate strong magnetic fields in the vicinity of the →.

### Installation Attention

نشانی: تهران - خیابان سعدی جنوبی - چهارراه اکباتان ناظم الاطبای شمالی - پلاک ۱۶۷

تلفن: ۰۲۶۳۳۵۳۲۶ - ۰۲۶۳۳۹۵۹۳۲۶ - ۰۲۶۳۳۵۳۲۱۹۴ - ۰۲۶۳۳۹۵۹۷۵۶ - ۰۲۶۳۳۹۵۹۷۵۶ - ۰۲۶۳۶۶۱۹۵۱۰ - ۰۲۶۳۶۶۱۹۳۹۰

<https://shop.cncparts.ir>



## Attention

1. Install the drive in a control cabinet that provides fire and electrical protection.
2. Please install the driver and motor in a location with sufficient weight resistance.
3. Please install this product in the following environment:
  - places without direct sunlight.
  - places where the ambient temperature does not exceed the product specifications.
  - places where the relative humidity does not exceed the product specifications and there is no condensation.
  - place free of corrosive or flammable gases.
  - places where there is little dust, dust, salt and metal powder.
  - place where there is no splash of water, oil, medicine, etc.
  - places where vibration or shock does not exceed the specifications of the product.There are no devices that generate strong magnetic fields in the vicinity of the →.
4. Do not block the air inlet and exhaust port, and do not let foreign matter enter the inside of the driver and motor.
5. Do not step on the product or place heavy objects on the drive.
6. Please install the driver in the specified direction.
7. Make sure that the drive is maintained at a defined distance between the inner surface of the control cabinet and other machines.

## Wiring Attention



## Attention

1. Do not use electromagnetic contactors when do the wiring between the driver and motor.
2. Please firmly connect the power terminal and the motor terminal.
3. The driver needs to keep a distance at least 10mm from the control cabinet or other equipment.
4. Leave at least 30mm of wiring space of the driver.
5. Please use twisted pair shielded cables for signal lines and encoder cables, with both ends of the shielding layer grounded.
6. The longest encoder cable length is 20m.
7. Minimize the frequency of power on/off as much as possible.

## Operation Attention



## Attention

1. To prevent accidents, please do a no-load (unconnected driver) trial run test on the servo motor. When installing on the machinery and starting operation, please pre-set parameters that match the machinery.
2. During JOG operation and Homing, the signals of positive limit (POT) and negative limit (NOT) are invalid. When using a motor on a vertical axis, please equip it with a safety device to prevent the work piece from falling off in the event of an alarm or over-travel. When an alarm occurs, please reset it after investigating the cause and ensuring safety.
3. Do not use the brake motor's brake for normal braking.

# CNC PARTS

## Version:

Version	Date	Content	Responsible person
V1.0	2023-12	First version	XIAO

نشانی: تهران - خیابان سعدی جنوبی - چهارراه اکباتان ناظم الاطبای شمالی - پلاک ۱۶۷

تلفن: ۰۲۱-۳۳۵۳۲۶۰۲ - ۳۳۹۵۹۳۲۶ - ۳۳۵۳۲۱۹۴ - ۳۳۹۵۹۷۵۶ - ۳۳۹۵۹۷۵۶ - ۳۶۶۱۹۵۱۰ - ۳۶۶۱۹۳۹۰

<https://shop.cncparts.ir>

## Content

Foreword .....	2
Safety Matters .....	3
Overall Cautions.....	3
Storage and Transport Attentions .....	3
Installation Attention.....	3
Wiring Attention .....	4
Operation Attention .....	4
Content .....	5
Chapter 1 Safety Instructions.....	7
1.1 Safety precautions.....	7
1.2 Wiring precautions.....	7
1.3 Precautions during operation.....	7
1.4 General precautions.....	8
Chapter 2 Overview.....	9
2.1 Product Overview.....	9
2.2 Arrival Inspection .....	10
2.2.1 check the full package and list.....	10
2.2.2 Attachment List.....	10
2.3 Name Rule.....	10
2.3.1 High-voltage model description .....	10
2.4 Hybrid servo driver technical parameters.....	10
Chapter 3 Installation Methods .....	14
3.1 Installation of high voltage pulse servo driver .....	14
3.1.1 Installation site .....	14
3.1.2 Installation environment conditions .....	14
3.1.3 Install reference size specifications .....	15
3.1.4 Installation method and precautions .....	16
Chapter FOUR. Connection instructions .....	17
4.1 System Connection.....	17
4.2 Servo driver main circuit wiring .....	19
4.2.1 Power terminals.....	19
4.2.2 Selection of regenerative braking resistor .....	19
4.3 Terminal Function.....	21
4.3.1 Power Supply/brake resistor/motor connector .....	21
4.3.2 RS232 serial port.....	22
4.3.3 Full-isolated RS485 communication terminal.....	22
4.3.4 Control Signal Terminal Connect .....	23
4.3.5 Encoder terminal connection .....	24
4.3.6 Motor brake control wiring diagram.....	25
4.4 Signal interface principle.....	25
4.4.1 Pulse input interface.....	25
Chapter 5: Keypad Display Panel Operation Instructions.....	28
5.1 Panel Function Keys .....	28
5.2 Panel Operation .....	28
5.3 Parameter Settings.....	29
Chapter SIX Keypad Display Panel Operation Monitoring and Parameter .....	30
6.1 Parameters Definition .....	30
6.2 Monitoring Status.....	30
6.2.1 Monitoring Status Content .....	30
6.2.2 Monitoring status description .....	31
6.3 Parameter table overview.....	32
6.3.1 Monitoring parameter table.....	32

نشانی: تهران - خیابان سعدی جنوبی - چهارراه اکباتان ناظم الاطبا شمالی - پلاک ۱۶۷

تلفن: ۰۲۶۳۵۳۲۶ - ۳۳۹۵۹۳۲۶ - ۳۳۵۳۲۱۹۴ - ۳۳۹۵۹۷۵۶ - ۳۳۹۵۹۷۵۶ - ۳۶۶۱۹۵۱۰ - ۳۶۶۱۹۳۹۰

<https://shop.cncparts.ir>

6.3.3	Basic Parameters .....	36
6.3.4	Communication Parameters.....	38
6.3.5	Extended parameters.....	39
Chapter 7: Power-on Operation .....		40
7.1	Selection of control mode.....	40
7.2	Basic Function Settings 7.2.1 Parameter default values are restored.....	41
7.2.2	Quick Jog Operation.....	41
7.2.3	Speed Trial Operation.....	41
7.2.4	Servo Enable Setting .....	42
7.2.5	Rotation Direction Switching.....	42
	Pulse Command Direction .....	43
7.2.6	Stop Mode Setting.....	43
	Inertial Stop .....	43
7.2.7	Power-loss brake (holding brake) .....	44
	Brake Power Disconnected, Motor in Position Locked State .....	45
7.3	Position Control.....	46
7.3.1	Position Control (External Pulse Command) .....	46
7.4	Speed Control.....	51
7.4.1	Speed arriving signal .....	51
7.4.2	Speed Selection.....	51
7.4.3	ACC/DEC Time.....	51
7.4.4	Operation Procedure .....	51
7.5	Torque Control.....	52
7.5.1	Torque Arriving Signal.....	52
7.5.2	Torque Threshold selection.....	52
7.5.3	Speed Selection.....	52
7.5.4	Related Parameters.....	53
7.6	Absolute Value System .....	53
7.6.1	Motor Zeroing.....	53
7.6.2	Power Loss and Low Voltage Exception Handling .....	53
7.6.3	Reading 32-bit Packed Position Data via Communication .....	55
7.6.4	Multi-Turn Zeroing.....	55
7.6.5	Servo Internal Homing.....	55
7.7.5.1	Homing Characteristics .....	55
7.7	Auxiliary functions.....	58
7.7.1	I/O input pin function configuration.....	58
7.7.2	I/O output pin function configuration.....	60
7.7.3	Anti-Blocking Protection .....	60
7.7.4	Current Output Limit.....	61
7.8	Test Operation .....	61
7.8.1	Operation Procedure .....	61
Chapter 8: Alarms and Handling .....		61
8.1	Alarm List .....	61
8.2	Alarm Solving Method .....	62
Chapter 9 MODBUS RTU Communication Instructions.....		69
9.1	Scope of Application.....	69
9.2	Protocol Format .....	70

نشانی: تهران - خیابان سعدی جنوبی - چهارراه اکباتان ناظم الاطبا شمالی - پلاک ۱۶۷

تلفن: ۰۲۶۳۵۳۲۶ - ۳۳۹۵۹۳۲۶ - ۳۳۵۳۲۱۹۴ - ۳۳۹۵۹۷۵۶ - ۳۳۹۵۹۷۵۶ - ۳۶۶۱۹۵۱۰ - ۳۶۶۱۹۳۹۰

<https://shop.cncparts.ir>

10.1 Motor model code comparison table.....	73
10.1.1 Five pole pairs motor model code.....	73
10.1.2 Four pole pairs motor model code.....	73

## Chapter 1 Safety Instructions

### 1.1 Safety precautions

Please follow the steps required in this manual for trial operation.

In the state of servo motor and mechanical connection, if operational errors occur, it can not only cause mechanical damage, but sometimes even lead to death.

Do not change the maximum speed value (H00-15) except for special purposes. If accidentally modified, it may damage the machinery or cause injury.

During the period of power on and after the power is cut off, the heat sink, external braking resistor, servo motor, and other components of the drive may experience high temperatures. Do not touch them, as they may cause burns. To prevent accidental contact between hands or components (such as cables), please take safety measures such as installing a casing.

When the servo motor is running, please never touch its rotating parts, otherwise it may be injured.

When installing on the supporting machinery and starting to operate, please place the servo motor in an emergency stop state at any time in advance, otherwise it may be injured.

Please install a stop device on the mechanical side to ensure safety.

The brake of a servo motor with a brake is not a stopping device used to ensure safety. If a stop device is not installed, it may result in injury.

If there is a momentary power outage and power is restored during operation, the machinery may suddenly restart, so please do not approach the machinery.

Please take measures to ensure that restarting does not endanger personal safety, otherwise it may result in injury.

Please never modify this product, as it may cause injury or mechanical damage.

Please install the servo drive, servo motor, and external braking resistor on non combustible materials, otherwise it may cause a fire.

### 1.2 Wiring precautions

When connecting the DO output to a relay, please pay attention to the polarity of the freewheeling diode, otherwise it will damage the driver and cause the signal to not output normally.

Please firmly connect the power terminal and signal terminal, otherwise it may cause a fire.

Please use twisted pair shielded cables for signal lines, with both ends of the shielding layer grounded.

Please take appropriate shielding measures in the following places, otherwise it may cause damage to the machine:

- ① When interference occurs due to static electricity;
- ② Places that generate strong electric or magnetic fields;
- ③ Places where there may be radiation exposure;
- ④ Places with power lines nearby.

### 1.3 Precautions during operation

During the trial operation, in order to prevent accidents, please conduct a no-load (not connected to the drive shaft) trial operation of the servo motor, otherwise it may cause injury.

When installing on the supporting machinery and starting operation, please pre-set user parameters

نشانی: تهران - خیابان سعدی جنوبی - چهارراه اکباتان ناظم الاطبا شمالی - پلاک ۱۶۷

تلفن: ۰۲۰۳۳۵۳۲۶ - ۳۳۵۳۲۱۹۴ - ۳۳۹۵۹۷۵۶ - ۳۳۹۵۹۷۵۶ - ۳۶۶۱۹۵۱۰ - ۳۶۶۱۹۳۹۰

<https://shop.cncparts.ir>

Due to extreme user parameter adjustments and changes in settings, the servo system's actions may become unstable. Therefore, please never make any settings, as it may cause injury. When an alarm occurs, please reset the alarm and restart the operation after eliminating the cause and ensuring safety, otherwise it may cause injury. Do not use the brake of the brake motor for normal braking, otherwise it may cause malfunction.

## 1.4 General precautions

This product is a general industrial product and is not intended for use in machines and systems that may affect human life.

Please have personnel with professional knowledge perform operations such as wiring, operation, maintenance, and inspection.

When selecting the tightening torque for screws during installation, please consider the strength of the screws and the material of the installation part, and choose the correct torque within a range that is not loose or damaged.

If applied to devices that may cause major accidents or losses due to the malfunction of this product, please equip with safety devices.

If applied to special environments such as atomic energy control, aerospace equipment, transportation equipment, medical devices, various safety devices, and equipment requiring high cleanliness, please contact our company.

Although this product has been fully managed in terms of quality, unexpected external noise, static electricity, input power, wiring, components, and other factors may cause unexpected actions in case of malfunction. Please fully consider mechanical safety measures to ensure safety within the possible range of movement in the workplace.

When the motor shaft operates without grounding, according to the actual mechanical and installation environment, the motor bearings may experience electrical corrosion, increased bearing noise, etc. Please confirm and verify on your own.

Based on the malfunction of this product, it may produce smoke from approximately one cigarette burning. If applied in environments such as purification workshops, please be sure to pay attention.

If applied in environments with high concentrations of sulfur or sulfurizing gases, please be aware that sulfurization may cause chip resistance breakage or poor contact at the contacts.

If the input voltage far exceeds the rated range of this product's power supply, smoking, fire and other phenomena may occur due to damage to internal components. Please pay full attention to the input voltage.

The matching of the structure, size, service life, characteristics, laws and regulations of the installation machine and components, as well as the matching of changes in the specifications of the installation machine, shall be ultimately decided by the user.

Please note that this product cannot guarantee use beyond the product specifications.

## Chapter 2 Overview

### 2.1 Product Overview

Servo drive technology has been developed for decades and has become increasingly mature with continuously improving performance. It is now widely used in automation fields such as CNC machine tools, printing and packaging machinery, inkjet photography, medical equipment, photovoltaic lithium batteries, textile machinery, 3C electronic equipment, and automated production lines.

The ES series hybrid servo system is a new generation of digital servo system independently developed by Shenzhen ECON Technology Co., Ltd. It adopts the latest processor DSP, high integration, small size, complete protection, and good reliability. The optimal PID algorithm is used to complete SVPWM control, and high-precision motor Sigma Delta current sampling is adopted. The chip has a built-in hardware current loop and a frequency division function module design, and its performance has reached the level of similar products at home and abroad.

The ES series hybrid servo system has the following characteristics:

- 1) The latest DSP with a main frequency of 600MHz.
- 2) High precision motor Sigma Delta (SDFM) current sampling, high current sampling accuracy, strong anti-interference ability.
- 3) Hardware current loop processing, faster efficiency.
- 4) IPM intelligent power module design.
- 5) With frequency division output, any frequency division, maximum frequency division output is 1MHz.
- 6) Pulse and direction signal commands support 5V or 24V differential/single-ended, 5V and 24V can be set through the driver selection switch.
- 7) 5 digital input signals, default common anode 24V input, default 5 digital inputs are enable, alarm clear, emergency stop, left limit, right limit, can be set as other input functions, please refer to the button display operation for details.
- 8) 2-channel digital output signal, default alarm separately, in place output.
- 9) Reserve 1 channel of 0-10V analog voltage input.
- 10) 1-channel motor brake control, the driver has a built-in relay, and the brake control port of the driver port is directly connected to the motor brake line.
- 11) Power supply voltage AC 220Vac, AC power supply range 90-253Vac, recommended AC 220Vac.
- 12) Built-in regenerative voltage discharge control circuit, but requires an external energy consumption discharge resistor. The driver has a low power discharge braking resistor built in.

نشانی: تهران - خیابان سعدی جنوبی - چهارراه اکباتان ناظم الاطبا شمالی - پلاک ۱۶۷

تلفن: ۰۲۰۳۳۵۳۲۶ - ۳۳۹۵۹۳۲۶ - ۳۳۵۳۲۱۹۴ - ۳۳۹۵۹۷۵۶ - ۳۳۹۵۹۷۵۶ - ۳۶۶۱۹۵۱۰ - ۳۶۶۱۹۳۹۰

<https://shop.cncparts.ir>

## 2.2 Arrival Inspection

### 2.2.1 check the full package and list

After receiving the goods, the following inspections must be carried out:

1. Whether the packaging box is intact and whether the goods have been damaged during transportation.
2. Check the nameplate of the high-voltage servo drive to ensure that the received goods are the ordered ones.
3. Check if the packing list and attachments are complete.

## Note

1. Damaged or incomplete servo drive systems cannot be installed.
2. If you have any questions after receiving the goods, please contact the supplier or our company.

### 2.2.2 Attachment List

- (1) 9PIN power/energy consumption/motor terminal plug
- (2) 2 \* 11P control signal terminal/encoder terminal dual row plug
- (3) Energy consumption relief vibration resistors can be optionally selected.

## 2.3 Name Rule

### 2.3.1 High-voltage model description

ES - 750 - □□□  
① ② ③

①	Series ES: Pulse high-voltage servo driver
②	Series name 100: 100W; 200: 200W; 400: 400W; 750: 750W; 1000: 1000W; 1500: 1500W; 2000: 2000W
③	Industrial/customized model/customized voltage

### 2.4 Hybrid servo driver technical parameters

Voltage	AC: 90~253Vac; standard 220Vac
power	400W~2KW
Control mode	SVPWM
Input pulse	5V/24V pulse, 600kHz

Electric gear ratio	200 ~ 51200, default 10000
Input signal	Pulse, 24VTTL, 5VTTL can be selected for the driver side selector switch, and frequent toggle is not recommended for the selector switch; Direction, 24VTTL, 5VTTL can be selected for the selector switch on the side of the driver, and the selector switch is not recommended to be toggled frequently; 5 digital inputs, 24VTTL.

نشانی: تهران - خیابان سعدی جنوبی - چهارراه اکباتان ناظم الاطبا شمالی - پلاک ۱۶۷

تلفن: ۰۲۰۳۳۵۳۲۶ - ۰۲۰۳۳۵۳۲۶ - ۰۲۰۳۳۵۳۲۱۹۴ - ۰۲۰۳۳۹۵۹۷۵۶ - ۰۲۰۳۳۹۵۹۷۵۶ - ۰۳۶۶۱۹۵۱۰ - ۰۳۶۶۱۹۳۹۰

<https://shop.cncparts.ir>

Output signal	1 alarm output, OC emitter output, output current 100mA, need pull-up level, maximum pull-up level 24V; 1 channel in place output, OC emitter output, output current 100mA, need pull-up level, the maximum pull-up level is 24V, can be set to motor brake control 1-way motor brake control, built-in driver inside, drive port directly connected to motor brake	
display	5-digit digital tube	
debugging	button, RS232 can also be debugged	
Communication port	Communication, Modbus protocol; reserve 1 way isolated RS485	
Load Inertia	Less than 20 times of the motor inertia	
Environment	Occasion	Indoor (avoid direct sunlight), should not be placed close to other heating equipment, should avoid dust, oil mist, corrosive gas and humidity, strong vibration places, prohibit flammable gas and conductive dust;
	Temperature(use)	-10~+40 (if temperature higher than 55, pls increase airiness)
	Storage temperature	- 20~ +65
	Density	40—90%RH , No condensation
	Installation	Vertical installation,parallel installation

Specification	Control way		Single phase: 220V full-wave rectification IPM SVPWM control Sinusoidal current drive mode	
	Matched motor encoder		17 bit or 23bit absolute	
	Use condition	use/storage Temp		-10~+40/-20~65 (If the ambient temperature is above 55, please force the surrounding ambient air circulation)
		use/storage density		Under 90%RH (no condensation)
		Vibration/shock resistance		4.9m/s <sup>2</sup> / 19.6/s <sup>2</sup>
		Protection class		IP20
		Pollution class		Level 2
		Altitude		Lower 1000m (higher 1000m, derating use)
		Load change rate		0~100% load: under±0.01%(rated speed)
		Speed change rate		0~100% load: ±0.01%
	Input signal performance	Voltage change rate		Rated voltage ±10% (rated speed)
		over-current ability		150% (rated current 1ms) , 200% (current 5s)
		Temperature change rate		25±25:under±0.1% (rated speed)
		speed control range		1:5000
		Frequency feature		<=800Hz
		Torque control accuracy		±1%
		Speed response	Un-load	10ms (zero speed to rated speed)
			Rated load	100ms (zero speed to rated speed)
		soft start time setting		0~10s (Acceleration and deceleration can be set separately)
		Speed control mode	The internal parameter sets the speed size	
IO input select speed			4 groups	
Internal parameters set torque		0~300%		

نشانی: تهران - خیابان سعدی جنوبی - چهارراه اکباتان ناظم الاطبا شمالی - پلاک ۱۶۷

تلفن: ۰۲۶۳۵۳۲۶۰ - ۰۲۶۳۳۹۵۹۳۲۶ - ۰۲۶۳۳۵۳۲۱۹۴ - ۰۲۶۳۳۹۵۹۷۵۶ - ۰۲۶۳۳۹۵۹۷۵۶ - ۰۲۶۳۶۶۱۹۵۱۰ - ۰۲۶۳۶۶۱۹۳۹۰

<https://shop.cncparts.ir>

Position control mode	Performance		Command smoothing mode	Low /S curve smoothing filter
			Feed forward	0~100%
			Position finished width	0~65535command unit ( set definition 1 pulse )
	Position command input	Command pulse	input pulse form	PUL+DIR; CCW/CW; A/B phase pulse
			Input form	differential drive Open-collector
			input pulse Frequency	Differential drive: 500Khz
			Command smoothing mode	Low pass filter /FIR filter
		pull-up output open-collector	The two outputs are pulled up to the external +24V 2KΩ resistor	
I/O signal	Digital input signal	Signal numbers	FIVE DI input	
		Function planning	I/O input function planning can be carried out	
		Signal Function	Servo enable, exception alarm clearing, speed reverse, pulse clearing, emergency stop, left and right limit, etc	
	Digital output signal	Signal numbers	2 DO output, 1 motor brake control output	
		Function planning	I/O output function planning can be carried out	
		Signal function	servo ready to output signals, complete positioning signal output, electromagnetic brake signal output, servo alarm signal output, torque arrival signal output/speed arrival signal output, Z pulse collector output	
Encoder feedback data	Single turn data		MODBUS RTU communication read	
	multi-turn data			
	32bit absolute position data			
	Frequency division output		QEP orthogonal encoding differential signal, arbitrary frequency division	
Built-in Function	Multiple mechanical origin reset functions		Multiple mechanical return to home methods	
	Electric gear ratio		$1/1000 \leq N/M \leq 1000$	
	electric regenerative braking	Brake mode	energy brake	
		brake resistor	internal or external	
	Protection function		Position deviation, over-speed, main circuit over-pressure/under-voltage, power module fault, abnormal braking circuit, over-current, overload, encoder signal interference, encoder disconnection, bus power abnormality, etc	
	Monitor function		Motor speed, current position pulse number, position command pulse number, position deviation, motor torque, motor current, running state, I/O signal, analog instruction/torque voltage, alarm memory, etc	

نشانی: تهران - خیابان سعدی جنوبی - چهارراه اکباتان ناظم الاطبا شمالی - پلاک ۱۶۷

تلفن: ۰۲۶۱۹۳۹۰ - ۰۲۶۱۹۵۱۰ - ۰۲۶۱۹۷۵۶ - ۰۲۶۱۹۷۵۶ - ۰۲۶۱۹۳۲۶ - ۰۲۶۱۹۳۲۶

<https://shop.cncparts.ir>

Display Operate

5 LED digit tube; 5 buttons



# CNC PARTS

نشانی: تهران - خیابان سعدی جنوبی - چهارراه اکباتان ناظم الاطبا شمالی - پلاک ۱۶۷

تلفن: ۰۲۰۳۳۵۳۲۶ - ۰۳۳۹۵۹۳۲۶ - ۰۳۳۵۳۲۱۹۴ - ۰۳۳۹۵۹۷۵۶ - ۰۳۳۹۵۹۷۵۶ - ۰۳۶۶۱۹۵۱۰ - ۰۳۶۶۱۹۳۹۰

<https://shop.cncparts.ir>

## Chapter 3 Installation Methods

Please read the "Safety Precautions" chapter and the installation matters introduced in this chapter carefully



- Please obey this chapter's installation requirements, or it will lead to driver damages or problematic
- Do not install the product that have damage or short of parts, or will lead to human harm.
- Do not install this product in a place where water will splash or in an environment prone to corrosion, otherwise it will cause product failure.
- It is strictly prohibited to install this product near flammable gas and combustible materials, otherwise it will cause fire or electric shock.
- Please install this product in an installation cabinet that can provide fire protection and electrical protection, otherwise it may cause a fire.
- Please ensure that the driver is kept at a specified distance from the inner surface of the control cabinet and other machines, otherwise it may cause fire or product failure.
- Do not place heavy objects on the product, otherwise it may cause personal injury or damage to the product.
- Do not apply excessive impact force to the equipment, otherwise it may cause product damage.
- It is strictly prohibited to block the suction and exhaust ports of the driver, and do not allow foreign objects to enter the product, otherwise it may lead to fire or product failure.

### 3.1 Installation of high voltage pulse servo driver

#### 3.1.1 Installation site

The life of the drive depends on the installation site. Please install it in a place that meets the following conditions. Do not use this product in corrosive environment such as hydrogen sulfide, sulfurous acid, chlorine, ammonia, chlorinated gas, acid, alkali, salt and other corrosive environment, flammable gas environment, combustible materials and other nearby. Please take good protection in places with oil mist, iron powder, grinding fluid, chips and so on. Stay away from heat sources such as stoves. Do not use the drive in a closed environment, which will cause high temperature and shorten the service life of the drive. A place that is easy to inspect and clean.

#### 3.1.2 Installation environment conditions

##### (1) Protection

The series of high voltage pulse servo drivers of JKON-TEK Company is not waterproof, so it must be prevented from dust, wood chips, iron chips and other metal chips when installed and used, and it must be prevented from icing and frosting in low temperature scenes, and oil stains.

##### (2) Temperature and humidity

The ambient temperature should be kept at  $-10^{\circ}\text{C}\sim 40^{\circ}\text{C}$  (no freezing or frost). The driver will heat up when running for a long time. Forced cooling should be considered when the surrounding space is small or there are heating devices nearby. The humidity should not be greater than 90%RH, and no condensation should occur.

##### (3) Vibration

The hybrid servo drive should not be installed in a vibrating environment, and the vibration should not be greater than  $0.5\text{G}(4.9\text{m/s}^2)$ .

### High-Voltage Servo Driver Installation Environment

Item	Specification
Using Environment	-10 ~ 40 °C (if the temperature exceeds 55°C, please strengthen the surrounding air circulation, low pressure 0°C operating environment can not freeze, can not frost)
Storage temperature	-20 ~ +65 °C
Operating environment / storage humidity	Below 90% RH (No frost)
Anti-vibration	0.15mm / 10 ~ 55Hz (not continuous use at resonance frequency)
Protection class	IP 20
Elevation	Attitude ≤ 1000M (above 1000M, pls reduce capacity)
Air pressure	86 ~ 106Kpa (test item can be selected)
Others	shall not be placed next to other heating equipment, dust, oil mist, corrosive gas, strong vibration field shall be avoided, and inflammable gas and conductive dust shall be prohibited

### 3.1.3 Install reference size specifications

The following is the installation size diagram of ES750 high voltage pulse servo driver (3D diagram please contact our technical personnel or dealer)

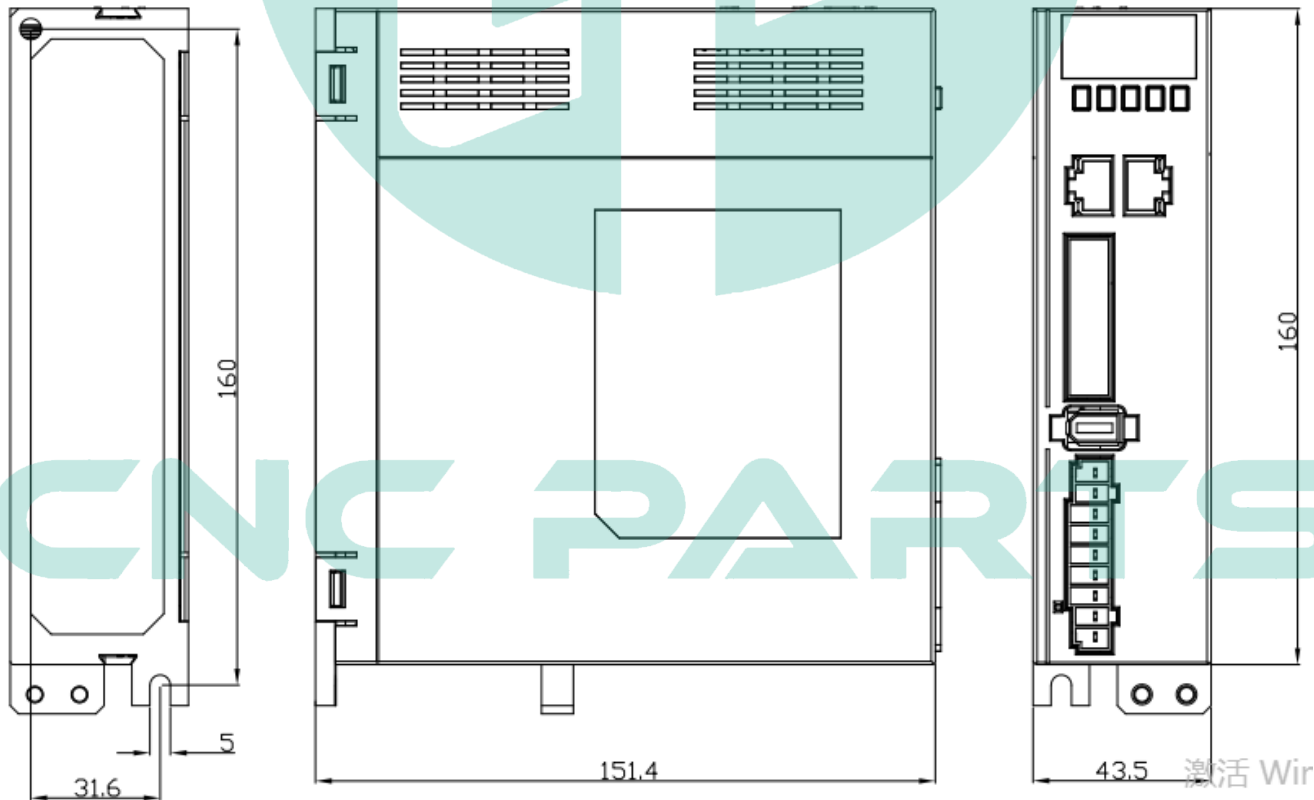

نشانی: تهران - خیابان سعدی جنوبی - چهارراه اکباتان ناظم الاطبای شمالی - پلاک ۱۶۷

تلفن: ۳۳۵۳۳۶۰۲ - ۳۳۹۵۹۳۲۶ - ۳۳۵۳۲۱۹۴ - ۳۳۹۵۹۷۵۶ - ۳۳۹۵۹۷۵۶ - ۳۶۶۱۹۵۱۰ - ۳۶۶۱۹۳۹۰

<https://shop.cncparts.ir>

The following is the external shape of ES750 high voltage pulse servo driver (3D diagram contact our technical personnel or dealer)

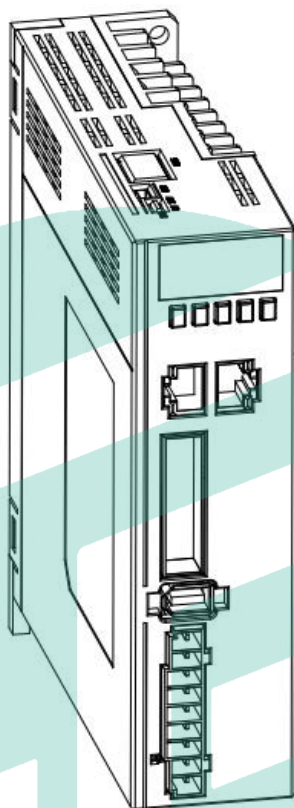

### 3.1.4 Installation method and precautions

(1) Installation method

The ES750 high-voltage pulse servo driver should be installed vertically , and the cabinet should be equipped with ventilation fan.

(2) Installation precautions:

When disassembling the drive, do not strike or crash the drive. ⚠

Pay attention to ventilation and heat dissipation, pay attention to the clean environment.

The following is the correct installation diagram of ES750 high voltage pulse servo driver in the control cabinet

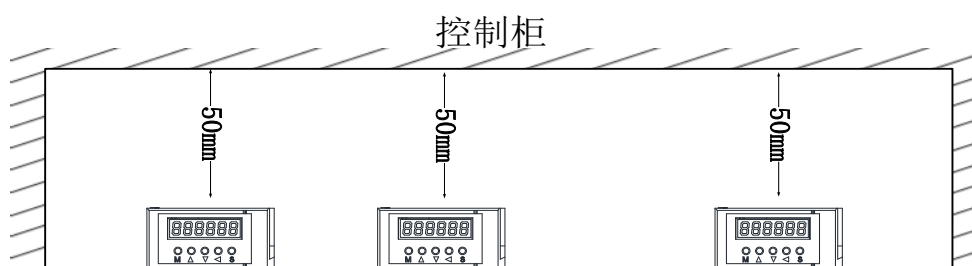



نشانی: تهران - خیابان سعدی جنوبی - چهارراه اکباتان ناظم الاطبای شمالی - پلاک ۱۶۷

تلفن: ۰۲۰۳۳۵۳۲۶ - ۰۳۳۹۵۹۳۲۶ - ۰۳۳۵۳۲۱۹۴ - ۰۳۳۹۵۹۷۵۶ - ۰۳۳۹۵۹۷۵۶ - ۰۳۶۶۱۹۵۱۰ - ۰۳۶۶۱۹۳۹۰

<https://shop.cncparts.ir>

## Chapter FOUR. Connection instructions

 Warning
<ul style="list-style-type: none"><li>• All personnel involved in wiring or inspection must have sufficient competence to perform this work.</li><li>• Wiring and inspection must be carried out one minute after the power is cut off to prevent electric shock.</li></ul>
 Be careful
<ul style="list-style-type: none"><li>• The terminals must be wired according to the voltage and polarity to prevent equipment damage or personnel injury.</li><li>• The driver and servo motor must be well grounded.</li></ul>

### 4.1 System Connection

# CNC PARTS

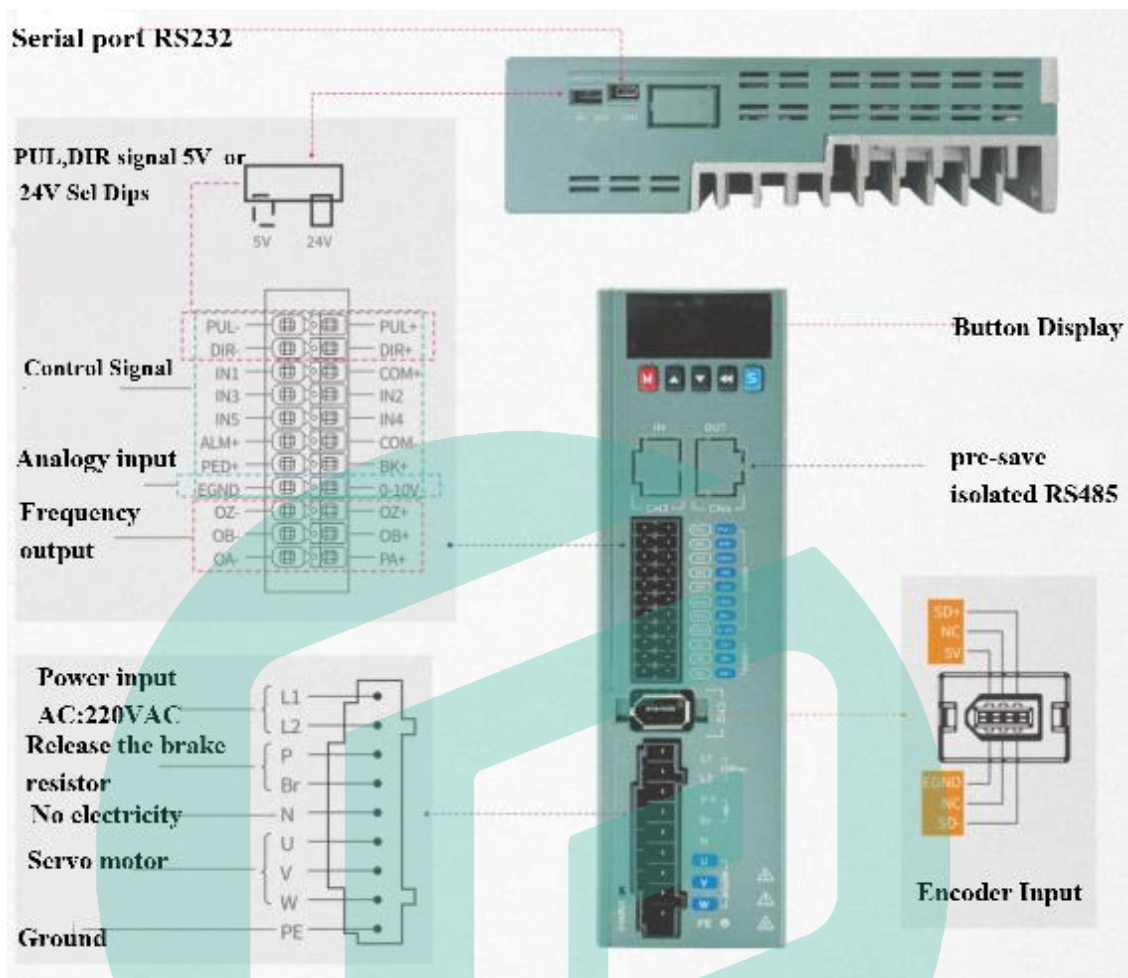

Note: 1.Pulse (PUL+/PUL-) and Direction (DIR+/DIR-) signal interfaces come factory default to support 24V signals. If the signal is 5V, check the BM selection switch on the side of the driver and adjust it to the 5V setting. Whether it's a 5V signal level or a 24V signal level, both differential and single-ended signal inputs are accepted. The signal cable length should be as short as possible, with single-ended signal control not exceeding 3 meters and differential signal control cable length not exceeding 10 meters. Signal cables must use twisted pairs with shielding, and should not be mixed with power cables or those with strong interference. The digital input signal (IN1, IN2, IN3, IN4, IN5, COM+ shared with common anode) of the

2.5 digital input signal is 24V. The digital input function is enabled by default, alarm clearing, emergency stop, left limit and right limit. Other functions can be set through the display button panel operation. For details, please refer to the display button operation instructions.

3.2 input channels, ALM+/COM-and PED+/COM-, respectively. Both outputs are OC emitter outputs, with a maximum drive current of 50mA per channel. A pull-up voltage is required, with a maximum pull-up level of 24Vdc and a pull-up resistor of 2K. The COM-common terminal is shared. If the load is an inductive load such as a relay, a

نشانی: تهران - خیابان سعدی جنوبی - چهارراه اکباتان ناظم الاطبا شمالی - پلاک ۱۶۷

تلفن: ۳۳۵۳۲۶۰۲ - ۳۳۹۵۹۳۲۶ - ۳۳۵۳۲۱۹۴ - ۳۳۹۵۹۷۵۶ - ۳۳۹۵۹۷۵۶ - ۳۶۶۱۹۵۱۰ - ۳۶۶۱۹۳۹۰

<https://shop.cncparts.ir>

reversed, it may damage the driver.

4.1 motor brake control output BK+/COM-, the two wires of motor brake (or clutch) are directly connected to BK+ and COM-. There is no relay in the middle. The relay is built-in in the driver. Please refer to the wiring diagram below for reference.

5. reserve a 0~10V analog input. The positive signal of the analog signal is connected to terminal 0~10V, and the negative electrode of the analog signal is connected to terminal EGND.

6.1 encoder frequency division differential output, OA+/OA-, OB+/OB-, OZ+/OZ-.

7. the reserved isolation RS485 bus is designed with full internal electrical isolation

8.the energy dissipation resistor must be correctly connected and used,

9. Try to arrange non-fuse (NFB) circuit breakers so that the external power supply can be cut off in time when the driver fails

## 4.2 Servo driver main circuit wiring

### 4.2.1 Power terminals

Wire diameter: ES750 power cord and servo motor connection wire have the same wire diameter, two power cords L1/L2, motor cable U/V/W cable choose AWG16. Energy dissipation resistor interface P and BR cable choose AWG16. [?]

It is suggested that the power supply should be powered by a noise filter to improve the anti-interference ability. [?]

Please install non-fuse (NFB) circuit breakers to cut off the external power supply in time when the driver fails.

### 4.2.2 Selection of regenerative braking resistor

If theoretical selection is required, we need to be able to specify the reciprocating motion cycle in practical application, acceleration and deceleration conditions, motor speed, load and motor inertia ratio, and maximum energy absorption of bus capacitor regeneration.

(1) When there is no external load torque and only horizontal shaft motion exists, it can be confirmed whether to need an external regenerative resistor according to the following simple calculation method.

(2) Reset the operating scene. For the dual Y-axis operating scene, it is recommended to connect an energy dissipation resistor outside the driver,

[?] Theoretical selection process of brake resistor:



نشانی: تهران - خیابان سعدی جنوبی - چهارراه اکباتان ناظم الاطبا شمالی - پلاک ۱۶۷

تلفن: ۰۲۰۳۳۵۳۲۶ - ۳۳۹۵۹۳۲۶ - ۳۳۵۳۲۱۹۴ - ۳۳۹۵۹۷۵۶ - ۳۳۹۵۹۷۵۶ - ۳۶۶۱۹۵۱۰ - ۳۶۶۱۹۳۹۰

<https://shop.cncparts.ir>

N为负载与电机惯量比

Discussion based on regenerative resistance calculation

The following figure shows the calculation steps of regenerative resistance capacity during acceleration and deceleration of the operating cycle

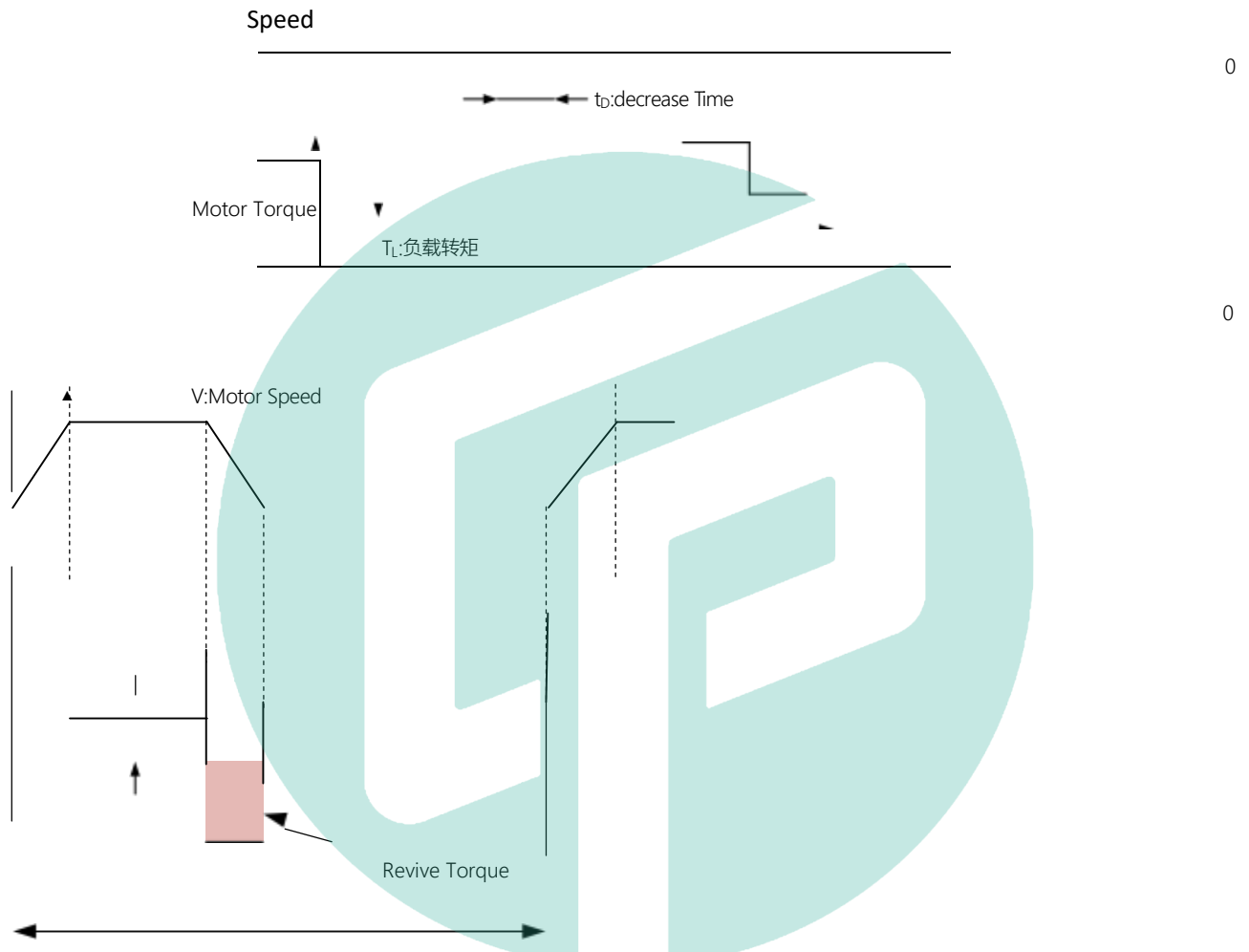

If the driver reports an over-voltage error, reduce the regenerative energy power or increase the resistance value and power specification.

# CNC PARTS

## 4.3 Terminal Function

### 4.3.1 Power Supply/brake resistor/motor connector

Terminal	Example	PIN	Signal	Input/Output	Description
Power motor Wiring connector		1	L1	Input	Power AC input,220Vac Power supply range 90-253Vac
		2	L2	Input	Power AC input,220Vac Power supply range 90-253Vac
		3	P	output	Connect one end of the release brake resistor
		4	Br	Output	Connect another one end of the release brake resistor
		5	N		NO any electricity
		6	U	Output	Servo motor winding U
		7	V	Output	Servo motor winding V
		8	W	Output	Servo motor winding W
		9	PE	Input	ground

Note: Matched plug: plug 9PIN 5.0MM

### 4.3.2 RS232 serial port

terminal	Example	Description
CN1		Please use our dedicated serial debugging line and debugging software. Do not insert it with power on. It needs to be inserted in the case of power off. After setting the parameters, you can pull it out

### 4.3.3 Full-isolated RS485 communication terminal

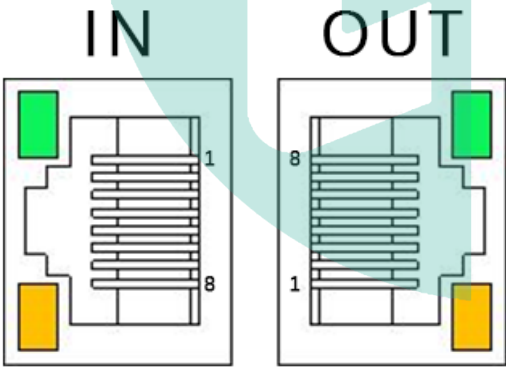
Terminal	Example	PIN	Signal	Description
CN3/CN4		7	RS485B IN/OUT definition same	485B bus,pre-save , electricity full isolated
		8	RS485A IN/OUT definition same	485A bus,pre-save , electricity full isolated

#### 4.3.4 Control Signal Terminal Connect

Terminal	Display	PIN	Signal	IN/Out	Description
Control signal terminal		1	PUL+	IN	High-speed digital differential pulse input, 5V or 24V,500KHz,default24V. If the signal level is 5V, it can be set to 5V by selecting the switch on the side of the driver BM
		2	PUL-	IN	High-speed digital differential pulse input, 5V or 24V,500KHz,default24V. If the signal level is 5V, it can be set to 5V by selecting the switch on the side of the driver BM
		3	DIR+	IN	High-speed digital differential reverse input, 5V or 24V,500KHz, default 24V. If the signal level is 5V, it can be set to 5V by selecting the switch on the side of the driver BM
		4	DIR-	IN	High-speed digital differential reverse input, 5V or 24V,500KHz, default 24V. If the signal level is 5V, it can be set to 5V by selecting the switch on the side of the driver BM
		5	COM+	IN	The 5 digital input signals share COM+, and the common anode is 24V by default
		6	IN1	IN	The default motor enables the input, and the signal is connected to the motor lock shaft. Other functions can be set, refer to the display button panel parameter description
		7	IN2	IN	The default emergency stop input is connected to the motor emergency stop. Other functions can be set. Refer to the display button panel parameter description
		8	IN3	IN	The default fault clearing reset input is connected to the signal for fault clearing and driver reset. Other functions can be set, refer to the display button panel parameter description
		9	IN4	IN	The default left limit input can be set to other functions. Refer to the display panel parameter description for reference
		10	IN5	IN	The default right limit input can be set to other functions. Refer to the display panel parameter description for reference
		11	COM-	OUT	The alarm output ALM+, brake control BK+, and in-position output PED+ share a common COM-.
		12	ALM+	OUT	The default alarm signal is OC emitter output, requiring a pull-up level with a maximum pull-up voltage of 24V and a maximum pull-up resistance of 2KΩ. It can be configured for other functions.
		13	BK+	OUT	The motor brake control has a relay already built into the driver, eliminating the need for an external relay. The two control wires of the motor brake

				should be directly connected to the BK+ and COM- terminals on the driver. Please refer to the motor brake wiring diagram for details.
	14	PED+	OUT	The default in-position signal is OC emitter output, which requires a pull-up level with a maximum pull-up voltage of 24V and a maximum pull-up resistance of 2KΩ. It can be configured for other functions.
	15	0-10V	IN	Pre-save
	16	EGND	IN	Analogy input 0-10V
	17	OZ+	IN	
	18	OZ-	OUT	The encoder's differential output supports frequency division, enabling arbitrary frequency-divided output.
	19	OB+	OUT	
	20	OB-	OUT	
	21	OA+	OUT	
	22	OA-	OUT	

Note: matched plug: dual-row plug 2\*11P, 3.5MM

#### 4.3.5 Encoder terminal connection

The encoder terminal on CN2 serves the same function as the encoder input in the control signal terminal. You only need to connect the encoder to one of them.

Terminal	Display	PIN	Signal	Description
CN2		1	EGND	E5V refer to negative
		2	E5V	provide 5V power to servo motor encoder
		3	NC	No electricity connect



24

نشانی: تهران - خیابان سعدی جنوبی - چهارراه اکباتان ناظم الاطبا شمالی - پلاک ۱۶۷

تلفن: ۰۲۰۳۳۵۳۲۶ - ۰۳۳۹۵۹۳۲۶ - ۰۳۳۵۳۲۱۹۴ - ۰۳۳۹۵۹۷۵۶ - ۰۳۳۹۵۹۷۵۶ - ۰۳۶۶۱۹۵۱۰ - ۰۳۶۶۱۹۳۹۰

<https://shop.cncparts.ir>

	4	NC	No electricity connect
	5	SD-	Absolute encoder SD-
	6	SD+	Absolute encoder SD+

#### 4.3.6 Motor brake control wiring diagram.

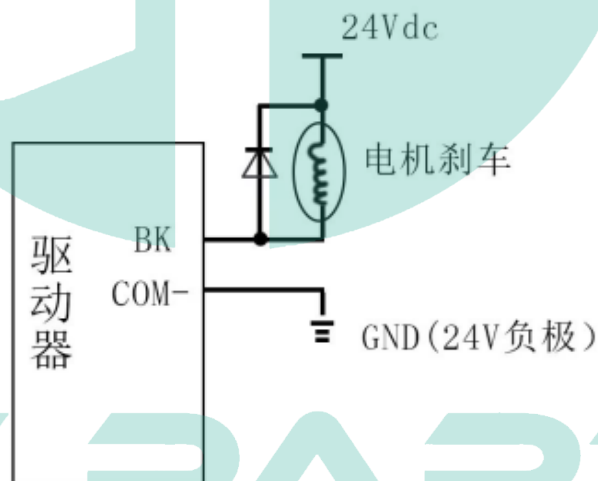

Note: The motor brake control wires should be directly connected to the BK and COM- terminals on the driver. Please refer to the diagram above for guidance. The relay is already built into the driver.

## 4.4 Signal interface principle.

### 4.4.1 Pulse input interface

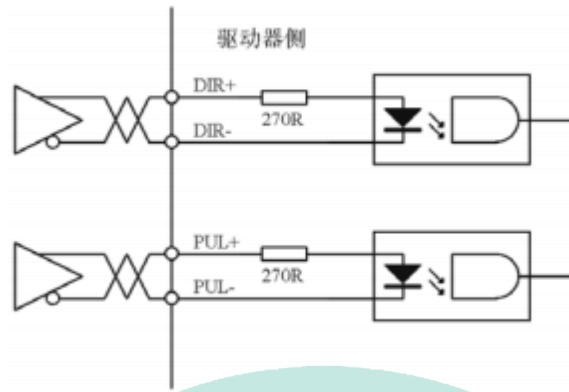

Differential driving method for pulse input interface.

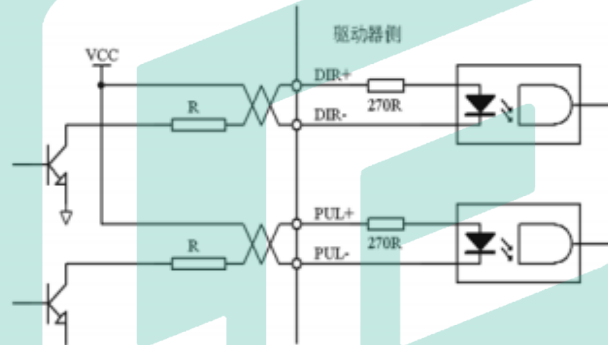

Single-ended driving method for pulse input interface

(1) The pulse and direction interface supports both 5V and 24V, with the factory default set to 24V. If a 5V signal level is required, it can be configured to 5V using the BM selection switch on the side of the drive.

(2) Keep the cable length as short as possible. For single-ended signal control, the cable should not exceed 3 meters, and for differential signal control, the cable should not exceed 10 meters. Signal cables must use twisted pairs and include a shielding layer.

(3) Details of the pulse input forms are shown in the table below. Arrows indicate the counting edge, which represents the pulse input timing and parameters. When using the 2-phase input form, the pulse frequency should be  $\leq 200\text{kHz}$ .

### PUL+DIR Input Form

PUL command form	CCW	CW	Parameters set
PUL row symbol			<b>PUL+DIR</b> Single pulse mode

PUL command form	CCW	CW	Parameters set
PUL row symbol			<b>PUL+PUL</b> Double pulse mode

### Pulse input timing parameters

Parameter	Differential drive input	Single-end drive input
$t_{ck}$	$> 2\mu s$	$> 5\mu s$
$t_h$	$> 1\mu s$	$> 2.5\mu s$
$t_l$	$> 1\mu s$	$> 2.5\mu s$
$t_{rh}$	$< 0.2\mu s$	$< 0.3\mu s$
$t_{rl}$	$< 0.2\mu s$	$< 0.3\mu s$
$t_s$	$> 1\mu s$	$> 2.5\mu s$
$t_{qck}$	$> 8\mu s$	$> 10\mu s$
$t_{qh}$	$> 4\mu s$	$> 5\mu s$
$t_{ql}$	$> 4\mu s$	$> 5\mu s$
$t_{qrh}$	$< 0.2\mu s$	$< 0.3\mu s$
$t_{qrl}$	$< 0.2\mu s$	$< 0.3\mu s$
$t_{qs}$	$> 1\mu s$	$> 2.5\mu s$

Timing diagram for pulse + direction input interface (maximum pulse frequency 200kHz)

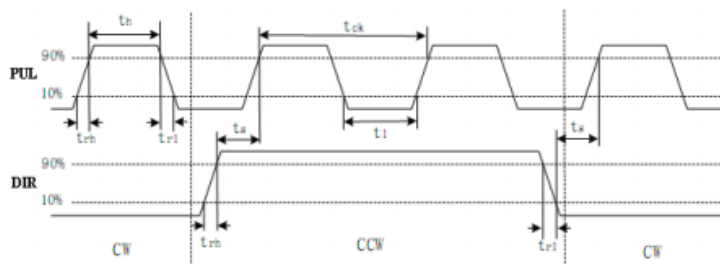

## Chapter 5: Keypad Display Panel Operation Instructions

### 5.1 Panel Function Keys

The drive unit panel consists of 5 LED digital displays and 5 keys, which are used to display various statuses, set parameters, and more.

The functions of the keys are as follows:

- ▲: Up, Increases the serial number or value, or moves the selection forward
- ▼: Down, Decreases the serial number or value, or moves the selection backward
- SET: M confirmation, Enters the next level of the operation menu or confirms input
- MODE: S setting, Returns to the previous level of the operation menu or cancels the operation
- ←: Shift, Moves the flashing digit to the left

Note: Holding down the key will repeat the operation, and the longer it is held, the faster the repetition rate becomes

### 5.2 Panel Operation

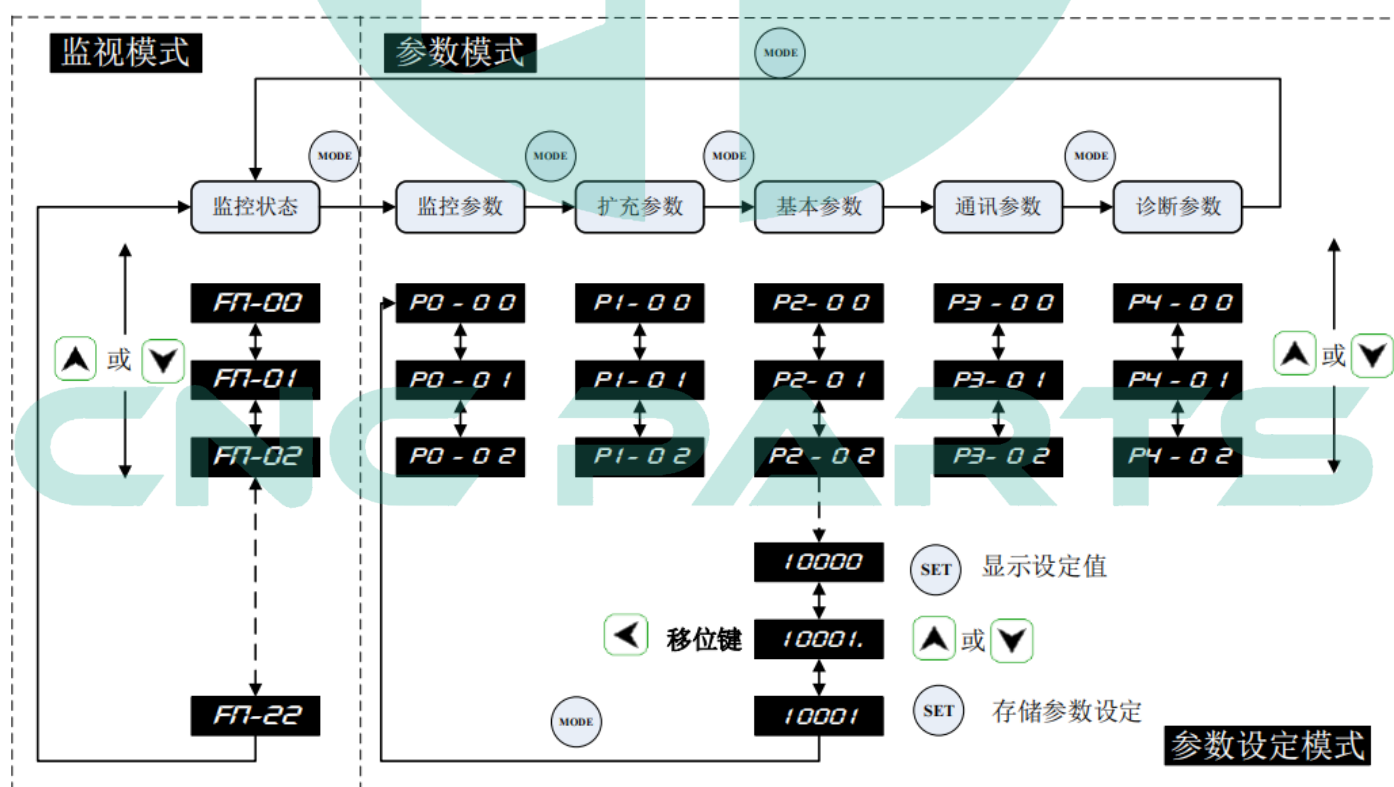

(1) When the drive power is turned on, the display will continuously show the monitoring display symbol for one minute before entering the speed monitoring display mode.

(2) In the monitoring mode Fn-xx, press the ▲ or ▼ key to switch between monitoring parameters.

(3) In monitoring mode, pressing the "M" key allows free switching between monitoring mode and parameter mode. In parameter mode, press the ▲ or ▼ key to change the last two characters of the parameter code.

(4) In parameter mode, press the "S" key to enter the setting mode. The display will show the setting value corresponding to the parameter. At this point, you can use the ▲ or ▼ keys to modify the parameter value or press the "M" key to exit the setting mode and return to parameter mode. When modifying a parameter, a decimal point will appear at the lower right corner of the parameter value.

(5) After completing the modification of the setting value, press the "S" key to save the parameter or execute the command.

(6) After completing the parameter setting, the decimal point on the display will disappear. Press the "M" key to switch to other parameters or monitoring modes.

(7) In the edit setting mode, press the ← key to cyclically move the flashing decimal point to the left, and use the ▲ or ▼ keys to quickly modify higher setting values.

### 5.3 Parameter Settings

Restore Default Values:

When the product leaves the factory, each motor model has corresponding motor parameters set in the system development platform. There are two methods to restore the default parameters:

1. Set the P1-05 parameter value according to the motor model code, and then set P0-02 to 1. The current parameter values will automatically restore to the default values.

#### ■ Related Parameters

Relevant Parameters	Name	UNIT	Parameters Range	Default Value	Applicable method.
P1-05	Motor model code		1~200	0	Pt, s
P0-02	operating code		0~2	0	Pt, s

2: Set the P1-05 parameter value according to the motor model code. After modifying it, press and hold the "SET" key for about 3 seconds, and the current parameter values will automatically restore to the default values.

Note: Refer to the appendix for the motor model code.

# CNC PARTS

First menu	Function description	Second menu	Content	Communication ADD (Decimal.)
------------	----------------------	-------------	---------	------------------------------

## Chapter SIX Keypad Display Panel Operation Monitoring and Parameter

### 6.1 Parameters Definition

Parameters are divided into the following five major categories. The first character following the parameter start code "P" is the group character, and the next two characters are the parameter characters. The communication address is formed by combining the hexadecimal values of the group character and the two parameter characters. The definitions of the parameter groups are as follows:

Group Parameters	Parameters Category	Function Description
Fn-00~Fn-23	Monitor status	Displayed status information, such as speed, current, etc.
P0-00~P0-08	Monitor parameters	Display the software and hardware versions of the system development platform and restore factory parameters.
P1-00~P1-64	Extended parameters	Setting the corresponding parameters can extend some functions of the system development platform, etc.
P2-00~P0-89	Basic parameters	Common user parameter settings, such as three-loop parameters, integration time, etc.
P3-00~P3-06	Communication parameters	Enable communication with the host computer, such as 485 communication.
P4-00~P4-62	Extended parameters	Extended parameter settings for control modes and diagnostics of some alarms.

### 6.2 Monitoring Status

#### 6.2.1 Monitoring Status Content

In the first-level menu, press the "M" key to switch to the first-level menu of the monitoring status. The user can use the  $\leftarrow$  or  $\rightarrow$  keys to select the desired display mode, then press the "S" key to enter the second-level menu of the monitoring status, where specific status information can be displayed.

<b>Fn - 01</b>	Lower bits of single-turn data for absolute encoder	<b>P 5806</b>	Current Position 145806	4x1281
<b>Fn - 02</b>	higher bits of single-turn data for absolute encoder( $\times 10000$ pulse)	<b>P. 14</b>	Pulse	4x1282
<b>Fn - 03</b>	Lower 4 bits of position command (pulse).	<b>C 5810</b>	Position command145810	4x1283
<b>Fn - 04</b>	Higher 4 bits of position command.( $\times 10000$ pulse)	<b>C. 14</b>	pulse	4x1284
<b>Fn - 05</b>	Lower 4 bits of position deviation (pulse).	<b>E 4</b>	Position deviation 4 pulses.	4x1285
<b>Fn - 06</b>	Higher 4 bits of position deviation.( $\times 10000$ pulse)	<b>E. 0</b>		4x1286
<b>Fn - 07</b>	Position command pulse frequency. (kHz)	<b>F 12.6</b>	Position command pulse frequency.12.6kHz	4x1287
<b>Fn - 08</b>	Motor speed (r/min)	<b>R 1000</b>	Motor speed 1000r/min	4x1288
<b>Fn - 09</b>	Current loop U-phase sampling reference voltage.	<b>U1.500</b>	U-phase sampling reference voltage is.1.5V	4x1289
<b>Fn - 10</b>	Current loop W-phase sampling reference voltage	<b>U 1.500</b>	W-phase sampling reference voltage is 1.5V	4x1290
<b>Fn - 11</b>	DC bus voltage on the main circuit side	<b>U310</b>	DC bus voltage is 310V	4x1291
<b>Fn - 12</b>	Torque analog command input (%)	<b>T. 25</b>	Torque analog command 25%	4x1292
<b>Fn - 13</b>	Average current (A)	<b>I 2.3</b>	Average current 2.3A	4x1293
<b>Fn - 14</b>	Peak Torque	<b>t. 1.27</b>	Peak Torque 1.27N.m	4x1294
<b>Fn - 15</b>	Lower bits of multi-turn data for absolute encoder	<b>A 3265</b>	Rotor absolute position value 3265	4x1295
<b>Fn - 16</b>	Higher bits of multi-turn data for absolute encoder	<b>A. 0</b>		4x1296
<b>Fn - 17</b>	Input terminal status	<b>1111111111</b>	Input terminal	4x1297
<b>Fn - 18</b>	Output terminal status	<b>1111111111</b>	Output terminal	4x1298
<b>Fn - 19</b>	Encoder value input signal	<b>Cod --</b>	Encoder signal	4x1299
<b>Fn - 20</b>	Servo operating status	<b>Rn On</b>	Is operating	4x1300
<b>Fn - 21</b>	Alarm code	<b>ALE 9</b>	Alarm 9	4x1301

### 6.2.2 Monitoring status description.

☐Encoder Single-Turn data = (Fn -02)  $\times$ 10000 + (Fn -01)

☐Encoder multi-turn data = (Fn -16)  $\times$ 10000 + (Fn -15)

☐Pulse command = (Fn -04)  $\times$ 10000 + (Fn -03)

☐External deviation = (Fn -06)  $\times$ 10000 + (Fn -05)

☐Input signal status

Enter Fn-17 to check the input status of DI1-DI6

☐Output signal status

Enter Fn-18 to check the input status of DO1-DO5

### 6.3 Parameter table overview

#### 6.3.1 Monitoring parameter table

Parameter	Function code	Applicable method	Set range	Factory default value	UNIT	Communication ADD (Decimal)
P0-00	Software version	P S T		40 7	/	4x0000
P0-01	Hardware version	P S T		20 0	/	4x0001
P0-02	Parameter Default Value Restoration 0: No operation 1: Restore factory parameter settings 2: Set the zero position of the absolute encoder motor (for manufacturer use).	P S T	0~2	0	/	4x0002
P0-03	Software Reset 0: No operation 1: Servo software reset	P S T	0~1	0	/	4x0003
P0-04	Previous alarm code 1	P S T		0	/	4x0004
P0-05	Previous alarm code 2	P S T		0	/	4x0005
P0-06	Previous alarm code 3	P S T		0	/	4x0006
P0-07	Previous alarm code 4	P S T		0	/	4x0007
P0-08	Previous alarm code 5	P S T		0	/	4x0008

#### 6.3.2 Extended parameter table.

Parameter	Function Code	method	Set range	Factory default value	UNIT	Communication ADD (Decimal)
P1-00	Control Mode Selection Refer to the 7.1 Control Mode Definition Table for details.	PST	0~100	0	/	4x256
P1-01	Pulse Command Direction 0: Pulse command direction logic positive 1: Pulse command direction logic negative.	P	0~3	0	/	4x257
P1-02	External Pulse Train Command Input Form Setting 0: Pulse + direction 1: High active CCW/CW	P	0~7	0	/	4x258

	pulse 2: A/B phase pulse 3: Low active CCW/CW pulse.					
P1-03	Control Command Input Source Setting 0: Control command given by terminal 1: Control command given by ModBusRTU communication (e.g., RS-232, RS-485).	P S T	0~2	0	/	4x259
P1-04	Internal Servo Start Setting 0: Servo disabled 1: Servo enabled After setting this parameter, press and hold the "SET" key for about 3 seconds. When "SAVE" is displayed, it indicates that the parameter value has been saved; otherwise, the modified value is not saved	P S T	0~1	0	/	4x260
P1-05	Motor Model Code: When P0-02=1, the servo automatically restores the parameter factory values based on the motor model code.	P S T	0~100	2	/	4x261
P1-06	Lower bits of the electronic gear ratio numerator	P	7 1~3276	8192	/	4x262
P1-07	Higher bits of the electronic gear ratio numerator	P	7 1~3276	0	/	4x263
P1-08	Low bits of the pulse count per revolution for the host computer	P	7 1~3276	0	/	4x264
P1-09	High bits of the pulse count per revolution for the host computer	P	7 1~3276	0	/	4x265
P1-10	Electronic gear ratio denominator	P	7 1~3276	625	/	4x266
P1-11	Detector output pulse count setting	P S T	7 0~3276	2500	P/r	4x267
P1-12	Motor Stop Mode Function 0: Free stop, longer stopping time 1: Inertial stop, shorter stopping time 2: Reserved.	P S T	0~2	0	/	4x268
P1-14	IO input selection switch	P S T	0~1	0	/	4x270
P1-15	Hardware Current Loop Enable	P S T	0~1	0	/	4x271

	Switch 0: Software current loop 1: Hardware current loop, execution cycle is 10 times the carrier frequency					
P1-16	Motor over-speed alarm detection threshold	P S T	0~6000	3000	rpm	4x272
P1-17	Power-on brake release delay effective monitoring switch	P S T	0~1	0	/	4x273
P1-19	Torque output limit switch	T	0~1	0	/	4x275
P1-20	Servo processing method selection when torque is reached	T	0~1	0	/	4x276
P1-21	Current loop PI type selection	P S T	0~1	0	/	4x277
P1-22	Position deviation clearing method	P	0~1	0	/	4x278
P1-23	CCW/CW direction prohibition method	P S T	0~1	0	/	4x279
P1-24	DI input filter time	P S T	10~10000	10	0.1ms	4x280
P1-25	SSPD signal output turns ON when the motor speed exceeds this speed	S	-6000~6000	1000	rpm	4x281
P1-27	Position error detection switch	P	0~1	0	/	4x283
P1-28	Automatic Homing Mode Switch: 0: After the servo receives the enable signal, an external I/O trigger is required for homing. 1: After the servo receives the enable signal, it starts automatic homing. 2: Set the origin position directly using the current position of the absolute encoder (invalid for incremental encoders)	P S T	0~2	0	/	4x284
P1-29	Origin return mode	P S T	0~15	0	/	4x285
P1-30	First-stage high-speed origin return speed setting	P S T	-3000~3000	20 0	rp m	4x286
P1-31	Second-stage low-speed origin return speed setting	P S T	-3000~ 3000	50	rp m	4x287
P1-32	Third homing speed setting	P S T	-6000~6000	50 0	rpm	4x288
P1-33	Origin return offset revolutions	P S T	0~3276 6	0	×10000	4x289
P1-34	Origin return offset pulse count	P S T	0~3276	0	pulse	4x290

			6			
P1-35	Enable delay time	P S T	0~1000 0	5	ms	4x291
P1-36	ZSPD signal output turns ON when the position deviation is less than this pulse count	P	0~1000 0	10	pulse	4x292
P1-37	Positioning completion signal output delay time	P	0~1000 0	0	ms	4x293
P1-38	Digital IO Pin DI1 Function Configuration ① The second digit is the input pin configuration function code (refer to Table 5.3 for details). ② The third digit indicates that the corresponding servo I/O signal is forcibly enabled. ③ The fourth digit indicates that the corresponding servo I/O signal input is inverted.	P S T	0~1135	1	/	4x294
P1-39	Digital IO Pin DI2 Function Configuration (same as above).	P S T	0~1135	4	/	4x295
P1-40	Digital IO Pin DI3 Function Configuration (same as above).	P S T	0~1135	5	/	4x296
P1-41	Digital IO Pin DI4 Function Configuration (same as above).	P S T	0~1135	6	/	4x297
P1-42	Digital IO Pin DI5 Function Configuration (same as above).	P S T	0~1135	7	/	4x298
P1-47	Digital IO Output Pin DO1 Function Configuration ① The lower two digits are the output pin configuration function code (refer to Table 5.4 for details). ② The third digit indicates that the output is forcibly enabled. ③ The fourth digit indicates that the output level is inverted. ④ The output signal is in open-drain mode, with the positive terminal connected to the host computer's input port and the negative terminal connected to the host computer's 0V.	P S T	0~1135	1	/	4x303
P1-48	Digital IO Output Pin DO2	P S T	0~1135	2	/	4x304

	Function Configuration (same as above).					
P1-49	Digital IO Output Pin DO3 Function Configuration (same as above).	P S T	0~1135	3	/	4x305
P1-52	Parameter prohibited to change	P S T	0~1	0	/	4x308
P1-60	Motor rated current	P S T	0~1000	60	0.1A	4x316
P1-61	The current sampling circuit allows for the maximum current	P S T	0~3000	3500	0.01A	4x317
P1-62	Motor operation overload multiple 1	P S T	0~500	12	%	4x318
P1-63	Overload alarm delay time 1	P S T	0~3000	6000	S	4x319
P1-64	The default menu is displayed when powering on	P S T	0~30	7	/	

### 6.3.3 Basic Parameters

Parameters	Item	Suitable method	Parameter range	Default value	UNIT	Communication ADD
P2-00	Speed Control Gain Increasing the speed control gain can improve speed response performance; however, setting it too high may cause vibration and noise	P S T	0~1280	155	0.1	4x512
P2-01	Speed Integral Time Constant A smaller speed integral time constant can improve speed response and reduce speed control errors, but setting it too small may cause vibration and noise	P S T	1~3276	150	0.1ms	4x513
P2-02	Position control gain	P S	0~2000	280	0.01	4x514
P2-03	Load inertia ratio of the servo motor	P S T	0~1000	100	%	4x515
P2-04	Position control feed-forward gain	P	0~1280	0	0.1	4x516
P2-05	Feed-forward command low-pass filter cutoff frequency	P	1~2000	300	Hz	4x517
P2-06	Position error detection range	P	0~3276	600	×100	4x518
P2-08	Speed gain switching threshold at low speed	P S T	0~6000	100	rpm	4x520
P2-09	Speed gain switching coefficient	P S T	0~500	100	%	4x521
P2-10	Speed loop second integral time constant	P S T	0~3276	600	0.1ms	4x522
P2-11	Speed loop derivative time constant	P S T	0~100	0	%	4x523

P2-13	Current loop proportional gain	P S T	0~6000	1050	0.001	4x525
P2-14	Current integral time constant	P S T	1~3276 7	130	0.1ms	4x526
P2-15	Current feedback filter coefficient	P S T	1~2000	60	%	4x527
P2-16	Speed feedback filter coefficient	P S T	1~2000	500	%	4x528
P2-19	Speed Parameter Value Save Switch 0: When the host computer modifies parameters P4-44 to P4-47 via MODBUS, the system will not save the changes. 1: When the host computer modifies parameters P4-44 to P4-47 via MODBUS, the system will save the changes	P S T	0~1	0	/	4x531
P2-20	PI regulator type	P	0~1	0	/	4x532
P2-21	Torque switching threshold	S T	0~500	100	%	4x533
P2-22	Position deviation counter switching threshold	S T	0~3276 6	100	×100	4x534
P2-23	Position command smoothing function switch	P	0~2	0	/	4x535
P2-24	Position command smoothing filter coefficient	P	1~1000 0	200	/	4x536
P2-25	Acceleration/deceleration time type	S T	0~1	0	/	4x537
P2-26	Speed control acceleration time	S T	0~1000 0	300	ms	4x538
P2-27	Speed control deceleration time	S T	0~1000 0	300	ms	4x539
P2-29	Servo response maximum frequency	P S T	10~600	200	Hz	4x541
P2-30	Torque limit proportional coefficient	P S T	0~1000 0	1000	0.001	4x542
P2-33	Carrier frequency selection	P S T	0~1	0	/	4x545
P2-34	Given acceleration speed switching threshold	P S T	0~6000	100	rp m	4x546
P2-35	Given speed switching threshold	P S T	0~6000	100	rp m	4x547
P2-36	Internal position control acceleration time	P S T	0~1000 0	300	ms	4x548
P2-37	Internal position control deceleration time	P S T	0~1000 0	300	ms	4x549
P2-38	Motor speed detection point when stationary	P S T	0~1000	10	rp m	4x550
P2-40	Motor zero signal offset	P S T	0~360	0	0.1 度	4x552
P2-41	Motor pole pairs	P S T	1~20	4	/	4x553
P2-42	Current Torque Coefficient	P S T	0~3000	500	0.001	4x554

	The conversion relationship between the motor's output current and output torque. Please ensure the motor model code in P1-05 is set correctly		0			
P2-44	Module alarm delay time	P S T	0~100	25	0.1ms	4x556
P2-53	Speed loop output limit value	P S T	0~1000	500	0.001	4x565
P2-54	Current loop output limit value	P S T	0~2000	950	0.001	4x566
P2-55	Electromagnetic brake activation delay time	P S T	0~1000	1500	0.1ms	4x567
P2-56	Electromagnetic brake deactivation delay time	P S T	0~1000	10000	0.1ms	4x568
P2-57	Absolute encoder control command	P S T	1~5	2	/	4x569
P2-58	17-bit Encoder and 23-bit Encoder Selection 0: 17-bit 1: 23-bit	P S T	0~1	0	/	4x570
P2-66	Homing wait delay time	P S T	0~1000	50	ms	4x578
P2-67	Width of the Z pulse output from the absolute encoder feedback	P S T	0~3276	30	pulse	4x579
P2-69	Number of CRC error alarms for encoder communication	P S T	0~100	20	/	4x581
P2-85	Torque arrival output signal filter time	T	0~3276	100	0.1ms	4x597

### 6.3.4 Communication Parameters

P	Name	Method	Range	Default Value	UNIT	Communication ADD
P3-00	Station number setting	P S T	1~12	1		4x768
P3-01	Communication baud rate 0:4800 1:9600 2:19200 3:38400 4:57600 5:115200 6:128000 7:256000	P S T	0~7	3	/	4x769
P3-02	Communication Protocol 0: No checking 1+8+N+1; 1: Parity check 1+8+0+1;	P S T	0~5	0	/	4x770

	2: puppet check 1+8+E+1; 3: No check 1+8+N+2; 4: parity check 1+8+0+2; 5: puppet check 1+8+E+2;					
P3-03	Communication Error Handling 0: Alarm and stop immediately 1: Alarm and deceleration stop 2: Continue running	P S T	0~2	0	/	4x771

### 6.3.5 Extended parameters

P	Function code	Method	Range	Default value	Unit	Communication ADD (Decimal)
P4-00	Servo motor inching (JOG) control	JOG	0~6000	0	rpm	4x1024
P4-01	Speed given in test mode	OL	-6000~6000	100	rpm	4x1025
P4-02	Speed trial run starting speed	Sr	-6000~6000	0	rpm	4x1026
P4-03	Open-loop operating voltage	OP	0~31000	1395	0.01V	4x1027
P4-04	Open-loop operating speed	OP	0~3000	18	rpm	4x1028
P4-05	Speed filter cutoff frequency 1	P S T	1~32766	200	Hz	4x1029
P4-06	Speed filter cutoff frequency 2	P S T	1~32766	200	Hz	4x1030
P4-07	Positive direction internal torque limit coefficient	T	0~1000	1000	%	4x1031
P4-08	Torque arrival lower limit coefficient	T	0~1000	1000	%	4x1032
P4-09	Internal torque command 1 / Internal torque limit 1	T	0~500	15	%	4x1033
P4-10	Internal torque command 2 / Internal torque limit 2	T	0~500	20	%	4x1034
P4-11	Internal torque command 3 / Internal torque limit 3	T	0~500	20	%	4x1035
P4-42	IGBT over-temperature protection delay time	P S T	0~10000	20	0.1s	4x1066
P4-44	Internal speed control reference 1	S	-6000~6000	100	rpm	4x1068
P4-45	Internal speed control reference 2	S	-6000~6000	200	rpm	4x1069
P4-46	Internal speed control reference 3	S	-6000~6000	300	rpm	4x1070
P4-47	Internal speed control reference 4	S	-6000~6000	0	rpm	4x1071
P4-48	Internal speed control reference 5	S	-6000~6000	-300	rpm	4x1072
P4-51	Main circuit DC side over-voltage protection threshold.	P S T	0~1000	400	V	4x1075
P4-52	Main circuit DC side undervoltage protection threshold	P S T	0~1000	150	V	4x1076
P4-53	Main circuit over-voltage alarm delay time	P S T	0~10000	20	0.1s	4x1077
P4-54	Main circuit under-voltage alarm delay	P S T	0~10000	20	0.1s	4x1078

	time					
P4-55	Main circuit braking alarm delay time	P S T	0~10000	20	0.1s	4x1079
P4-56	Main circuit power loss alarm delay time	P S T	0~10000	20	0.1s	4x1080
P4-62	Encoder zeroing voltage	CO	0~100	30	V	4x1086

## Chapter 7: Power-on Operation

### 7.1 Selection of control mode

Control mode categories	Subcategories	P1-00 setting value	Description
Position	Pt	0	External position control
Speed	Si	2	Internal speed control
Torque	Ti	4	Internal torque control
TEST mode	Sr	11	Speed trial operation
	OL	13	Speed test mode
	OP	15	Open-loop operation (for manufacturer use)
Encoder home	CO	14	Encoder zeroing (used by manufacturer)
Others	Function customized	18~100	Dedicated customer or dedicated industry use

**Position** control is the control of inputting the pulse train command into the servo unit and moving it to the target position. Position instructions can be given by a combination of external pulse inputs, the total number of internally given position instructions, and speed limits. The position is controlled by the number of input pulses, and the speed is controlled by the frequency of the input pulses, which is mainly used in the occasions that require positioning control, such as manipulators, grinding machines, engraving machines, CNC machine tools, etc.

Speed control refers to the control of the speed of machinery through speed commands. By means of digital or analog voltages or communication of given speed commands, the system development platform enables fast and precise control of the speed of the machine.

Torque control refers to the control of the output torque of the motor through torque commands. Given torque commands can be given via digital, analog, voltage, or communication. The current of the servo motor has a linear relationship with the torque, so the control of the current can realize the control of the torque. The torque control mode is mainly used in devices that have strict requirements for the force of the material, such as some tension control occasions such as the winding and unwinding device, and the given value of torque should ensure that the force of the material is not affected by the change of the winding radius.

## 7.2 Basic Function Settings

### 7.2.1 Parameter default values are restored

☑ Procedure for operation

- 1) Set the parameter value of P1-05 according to the motor model code
- 2) Set P0-02 to 1
- 3) After the system development platform restores the default parameter values, it will automatically reset and restart the system

#### ■ Related Parameters

Parameters	Function Code	Method	Range	Default Value	UNIT	Communication ADD (Decimal)
P0-02	Restoration of parameter default values	P S T	0~2	0	/	4x0002
P1-05	Motor model code:	P S T	0~100	2	/	4x261

### 7.2.2 Quick Jog Operation

After powering on the system development platform, ensure that the current monitoring status displays "R 0". Press and hold the "S" key on the display panel for about 3 seconds to enable the servo. Then:

- Press and hold the "☐" key to rotate the motor counterclockwise
- Press and hold the "☐" key to rotate the motor clockwise
- Press the "M" key to disable the servo, causing the motor to stop

The jog speed can be adjusted by modifying parameter \*\*P4-00\*\*

### 7.2.3 Speed Trial Operation

Operation Procedure

1. Set parameter **P1-00 = 11** to enable the servo to operate in speed trial mode.
2. Set parameter **P1-04 = 1** to enable the servo.
3. Navigate to parameter **P4-02** and use the "▲" or "▼" keys to adjust the speed command.

4.The motor will run at the specified speed:"▲" increases the speed in the forward direction,"▼" decreases the speed in the forward direction (or increases it in the reverse direction).When the displayed speed is positive, the motor rotates forward;When the displayed speed is negative, the motor rotates in reverse.

#### 7.2.4 Servo Enable Setting

The servo enable signal determines whether the servo motor is powered and operational. When the servo enable signal is inactive, the motor is not powered and cannot run. The enable function can be controlled via external terminal signals or communication with an upper-level controller.

##### Internal Enable

In the absence of an external enable signal, the servo can be enabled by modifying parameter **P1-04**:Set **P1-04 = 1** to enable the servo,Set **P1-04 = 0** to disable the servo.

##### External Enable

When **P1-04 ≠ 1**, the servo can be enabled through the DI input signal of the control signal terminal. For example: If **DI1** is used as the enable signal, set the DI1 input function parameter **P1-38 = 1**. When **DI1 is low**, the servo is enabled;When **DI1 is high**, the servo is disabled.

##### Related Parameters

P	Function Code	Method	Range	Default Value	UNIT	Communication ADD (Decimal)
P1-04	Internal Servo Enable Setting - 0: Servo disabled - 1: Servo enabled  After setting this parameter, press and hold the "SET" key for about 3 seconds. When "SAVE" is displayed, the parameter value is saved. Otherwise, the modified value will not be saved	P S T	0~1	0	/	4x260
P1-38	Digital input terminal DI1 function configuration	P S T	0~1135	1	/	4x294

#### 7.2.5 Rotation Direction Switching

Users can change the rotation direction of the servo motor by adjusting parameter **P1-01**. The motor's rotation direction is defined as follows:

**Forward Rotation (CW):** Counterclockwise rotation (when facing the motor shaft).

**Reverse Rotation (CCW):** Clockwise rotation (when facing the motor shaft).

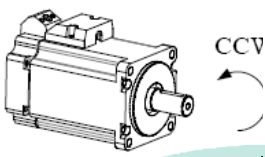
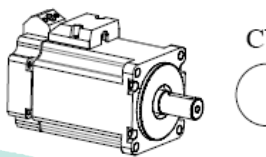
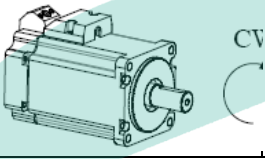
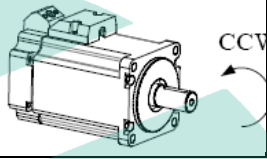
Mode	CW	CCW	P1-01 set
Standard Configuration CCW(Counterclockwise) is defined as forward rotation.			0
Reverse Mode CW (Clockwise) is defined as forward rotation			1

#### ■ Related Parameters

P	Function Code	Method	Range	Default Value	UNIT	Communication ADD (Decimal)
P1-01	<b>Pulse Command Direction</b> 0: Pulse command direction is logically positive 1: Pulse command direction is <b>logically negative</b>	P	0~3	0	/	4x257

### 7.2.6 Stop Mode Setting

The servo stop mode is divided into inertial stop and deceleration stop. Below is an explanation of these stop modes.

Stop Method	Inertial Stop	Deceleration Stop
Stop Principle	When the system development platform is disabled (servo not enabled), the servo motor is not powered, and it will decelerate freely to a stop. The deceleration time is influenced by factors such as: Mechanical Inertia, friction	When the system development platform outputs a reverse braking torque, the servo motor decelerates rapidly to a stop

Stop Features	<p>Advantages:1.Smooth Deceleration: The motor slows down gradually, ensuring a controlled and stable stopping process. 2.Reduced Mechanical Impact: Minimizes stress and wear on mechanical components, extending equipment lifespan.</p> <p>Disadvantages:Slower Deceleration Process</p>	<p>Advantages: Short deceleration time</p> <p>Disadvantages: Mechanical shock exists</p>
---------------	---	--

According to the different scenarios of servo shutdown, it is divided into servo OFF shutdown, alarm shutdown and over-travel shutdown.

### 1) Servo OFF and alarm shutdown

When the alarm code is 11 or 9, that is, the module is faulty or the coding fault, and the system development platform is not decelerating and stopping

STOP	P1-12 = 0	P1-12 = 1
Servo OFF	Inertial stop	Deceleration stop
Servo Alarm	inertial stop	Deceleration stop

### 2) Over-travel stop

P2-70	P2-63	P-0T	N-0T	Stop Mode
0:No check over-travel	x	x	x	Invalid
1:check over-travel	0	ON	OFF	CCW prohibited
	0	OFF	ON	CCW prohibited
	1	ON	OFF	CCW prohibited
	1	OFF	ON	CCW prohibited

### 3) Emergency Stop

When DI\_EMGS = ON, servo emergency stop, and servo alarm, alarm code Err -20

DI_EMGS	P1-12 = 0	P1-12 = 1
ON	Inertial stop	Deceleration stop
OFF	x	x

### 7.2.7 Power-loss brake (holding brake)

When the servo motor controls the vertical load, the purpose of using the "servo motor with power loss brake" is to make the moving part not move under the action of its own weight or external force when the power supply of the system is put to "OFF".

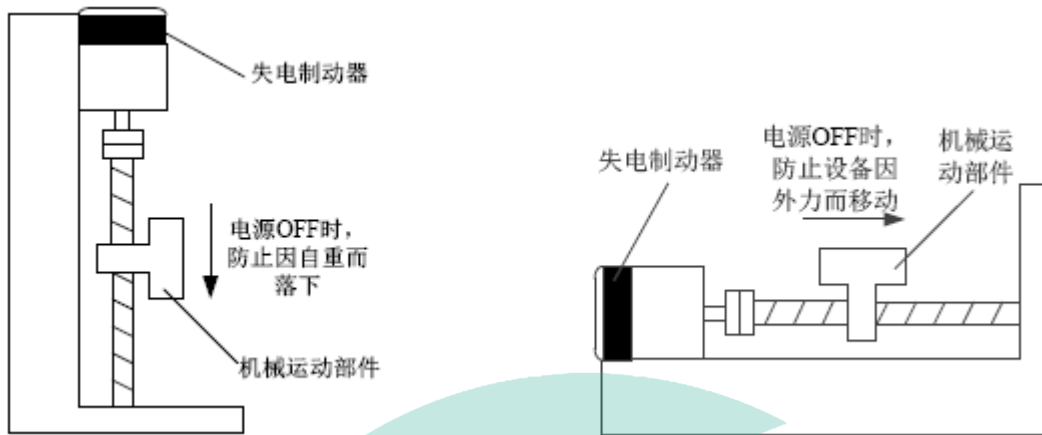

The brakes built into the servo motor are fixed special brakes with non-excitation action. It cannot be used for dynamic braking, so use it only when the servo motor is stopped.

### 1) Hardware connection

The sequential output signals "BRKR+", "BRKR-", and "Brake Power" of the servo unit constitute the ON/OFF circuit of the brake. A typical example of a connection is shown below.

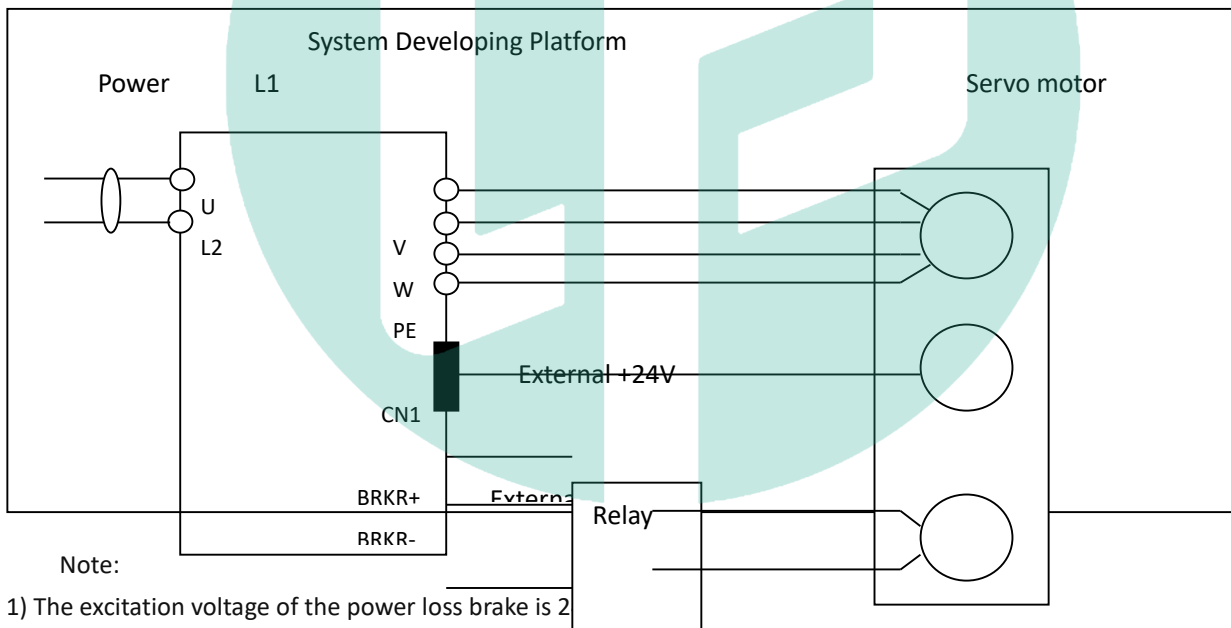

For servo motors with brakes, it is necessary to configure the DO terminal of the system development platform to output the BRKR function of the brake, and determine the effective logic of the DO terminal, that is, the parameters P1-40 need to be set.

Parameter setting status	Servo operate state	Signal DO/BRKR terminal output state	Servo motor state
P1-40 = 0	Disable	invalid	Brake Power Disconnected, Motor in Position Locked State

	Enable	valid	Brake power on, the power is under rotating state

### 3) Motor Brake Control Timing

Due to the delay in the brake's action, slight mechanical movement may occur under the influence of gravity or other forces. To address this, the **brake release delay time** can be adjusted using parameter **P2-55**, and the **brake engage advance time** can be adjusted using parameter **P2-56**.

When configuring a servo motor with a brake, the timing of the brake control output signal "BRKR" and the servo **SON** signal **ON/OFF** actions should follow the sequence shown in the diagram below. Specifically: Before the **BRKR** signal is output to release the brake, the servo motor must already be in the **powered and enabled state**. After the **BRKR** signal is stopped and the brake is engaged, the servo motor's power is then turned off.

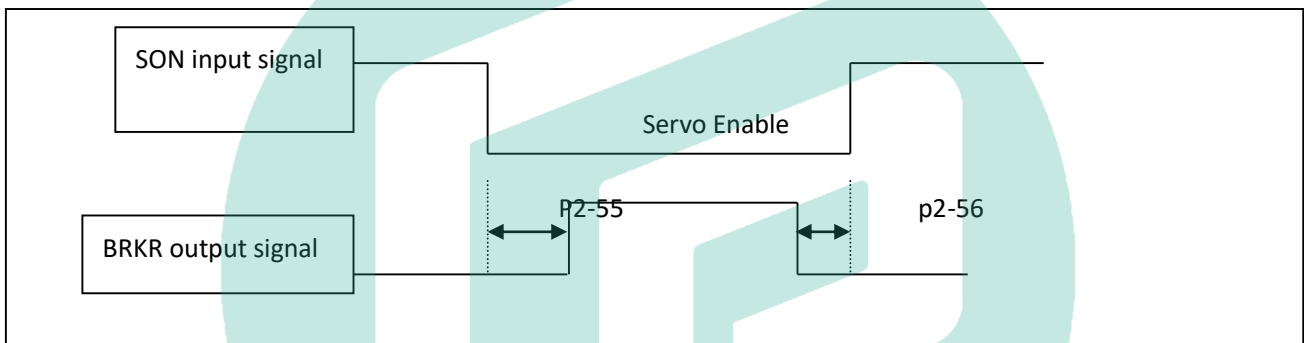

## 7.3 Position Control

### 7.3.1 Position Control (External Pulse Command)

#### 7.3.1.1 Electronic Gear Ratio

##### 1. Overview

The **electronic gear ratio** function is primarily used for two purposes:

(1) **Determine the number of command pulses required for the motor to rotate one revolution**, ensuring the motor speed meets the required specifications.

**Take an Example of 17-bit Encoder Motor:** The upper-level PLC sends a pulse frequency of **200 kHz**.

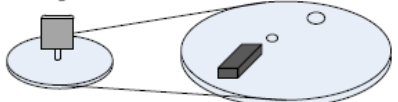
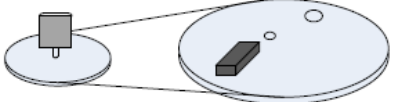
Rev/PUL set to 10000, electronic gear ratio set to 131072:10000	Rev/PUL set to 5000, electronic gear ratio set to 131072:5000
<p>The ratio of the radius of the large and small discs is 2:1. The large disc rotates 1 turn, then the small disc dragged by the motor rotates 2 times, and the large disc rotates 1 turn, and 20,000 pulses need to be sent</p>  <p>workpiece max speed is 600RPM</p>	<p>The ratio of the radius of the large and small discs is still 2:1, so for the large disc to rotate 1 revolution, only 10,000 pulses need to be sent</p>  <p>workpiece Max speed is 1200RPM</p>

(2) In precise positioning, the length of the physical unit corresponding to 1 command pulse is set for easy calculation.

As shown in the figure below, if the specified unit pulse corresponds to the workpiece moving 1um, the amount of instruction required for the load shaft to rotate one turn is 6mm/1um= 6000 command pulses, in the case of the reduction ratio of 1:1, the number of pulses per revolution can be directly set P1-08=6000, P1-09=0, then the host computer sends out 6000 pulses and the workpiece moves 6mm.

Do not change the electronic gear ratio case	Change the electronic gear ratio case
<p>Without changing the electronic gear ratio, the motor rotates 1 revolution to 131072 pulses (P1-07 = 1, P1-06 = 1 and P1-10 = 1). If the workpiece moves 6mm in 1 revolution, the number of pulses required is 131072, and if the workpiece moves 10mm, it takes <math>10/6 * 131072 = 218453.333</math> pulses, and the decimal number will be rounded when the pulse is actually sent, and an error will be generated.</p>	<p>By changing the electronic gear ratio, it takes 6000 pulses for 1 revolution of the motor. If the workpiece moves 6mm in 1 revolution, the number of pulses required is 6000 pulses, and if the workpiece moves 10mm, it takes <math>10/6 * 6000 = 10000</math> pulses.</p>

#### ■ Related Parameters

P	Function Code	Method	Range	Default Value	UNIT	Communication ADD (Decimal)
P1-06	Electronic gears are lower than the molecule	P	1~32767	8192	/	4x262
P1-07	Electronic gears are higher than molecules	P	1~32767	0	/	4x263
P1-08	PLC one round pulse numbers in low	P	1~32767	0	/	4x264
P1-09	PLC one round pulse numbers in high	P	1~32767	0	/	4x265
P1-10	electronic gear ratio numerator	P	1~32767	625	/	4x266

**Note:** The pulses per revolution (PPR) setting has higher priority than the electronic gear ratio setting. The electronic gear ratio parameters (P1-06, P1-07, and P1-10) will only take effect when both P1-08 and P1-09 are set to 0.

#### ■ Calculation of the electronic gear ratio

PLC one round PUL numbers	Gear ratio (P1-08=0 and P1-09=0)
① PLC per round PULSE numbers = (P1-09) × 10000 + (P1-08)	① gear ratio molecule = (P1-07) × 10000 + (P1-06) ② gear ratio = encoder resolution / command

<p>② If the PLC sends <b>1000 pulses</b> to make the servo motor rotate <b>one full revolution</b>, set the parameters as follows: <b>P1-09 = 0, P1-08 = 1000</b></p>	<p><b>PULSES</b></p> <p>③ if the PLC sends <b>1000 pulses</b> to make the servo motor rotate <b>one full revolution</b>, the electronic gear ratio can be calculated and configured as follows: <b>Calculation Encoder Resolution: 131,072 pulses per revolution</b> (for a 17-bit encoder).  <b>Desired Pulses per Revolution (PPR): 1000.</b>  The electronic gear ratio is calculated as:  <math>131072/1000</math>. Simplify the fraction to its lowest terms: <math>16384/125</math>.  <b>P1-07 (Denominator): Set to 125.</b>  <b>P1-06 (Numerator): Set to 16384.</b>  <b>P1-10 (Multiplier): Set to 1</b> (if applicable, depending on the system).</p>
---	---

### 7.3.1.2 Positioning Completion Signal

A signal that indicates the completion of servo motor positioning during position control. It is used when the command controller requires confirmation of positioning completion.

#### ■ Related parameters

P	Function Code	Method	Range	Default Value	UNIT	Communication ADD (Decimal)
6	P1-3 When the position error is less than the specified number of pulses, the ZSPD signal outputs ON	P	0~1000	1 0	pulse	4x292
7	P1-3 Positioning Completion Signal Output Delay Time	P	0~1000	0	ms	4x293
0	P1-5 Digital IO Output Pin D04 Function Configuration	P S T	0~1135	1	/	4x305

After the command ends, if the absolute value of the position error is below P1-36, the ZSPD signal is output. If the signal needs to be output from DO4, set P1-49 to 3. Note that a single DO4 terminal can only be used for one signal function.

#### ■ Position Width Explanation

(1) The positioning completion width (P5-00) changes proportionally with the variation of the electronic gear ratio. The factory default setting is 11 command units.

Take below chart as an example:

Motor rotate 1 circle need how many command pulses	Position completed Width P1-36
10000 (default)	11
20000	22
5000	6
3000	4
2000	3

The positioning completion width (P5-00) changes proportionally with the number of command pulses required for the motor to complete one revolution.

The output of the positioning completion signal depends on the positioning completion width. The smaller the width, the later the positioning completion signal is output, but the signal output does not affect the actual operating state of the motor.

(3) The positioning completion width can also be set independently, and changing it will not affect the number of command pulses required for the motor to complete one revolution.

### 7.3.1.3 Command Pulse Inhibit Signal

The position command inhibit function stops the input of command pulses during position control, including both internal and external position commands. When the DI\_INH signal is ON, the pulse commands are no longer counted.

### 7.3.1.4 Position Error Clear

Position Error = (Position Command - Position Feedback) (in encoder units)

The position error clear function allows the drive to clear the position error to zero when the servo is turned OFF or when the DI\_CLR signal is received.

#### ■ DI\_CLR Signal Description

When pulses are sent to the servo and the DI\_CLR input signal is executed, the servo will latch the current pulse count, update the encoder's current position to the position feedback in the control system, and clear all intermediate values in the position loop, speed loop, and current loop.

The DI\_CLR signal is edge-triggered.

### 7.3.1.5 Position Error Setting

The pulse error value refers to the difference between the command pulses from the command controller (e.g., PLC) and the feedback pulses from the servo unit in position mode. Its unit is 1 command unit, which is related to the command unit determined by the electronic gear ratio.

During position control, an alarm will be triggered if the pulse error exceeds a certain limit. This threshold is

the pulse error limit. When P1-27 is set to 0, the pulse error magnitude will not be detected.

■ Related Parameters

P	Function Code	Method	Range	Default Value	UNIT	Communication ADD (Decimal)
7	P1-2 Position Over-Error Detection Switch	P	0~1	0	/	4x283
6	P2-0 Position over-error check range	P	0~3276 7	60 0	×100	4x518

### 7.3.1.6 Position Command Filter

■ Related parameters

P	Function Code	Method	Range	Default Value	UNIT	Communication ADD (Decimal)
P 2-23	Position Command Smoothing Function Switch	P	0~2	0	/	4x535
P 2-24	Position Command Smoothing Filter Coefficient	P	1~10 000	20 0	/	4x536

### 7.3.1.7 Operation Process

- (1) Connect to CN2, ensuring the input control signal (SON) is in the OFF state.
- (2) Turn on the control circuit power (do not connect the main circuit power yet). The drive unit's display should light up, showing "r - 0" if there are no alarms. If an alarm appears, identify the cause and resolve it until no alarms are present.
- (3) Set the control mode selection parameter P1-00 to 0, and configure the appropriate electronic gear ratio (P1-06, P1-07, and P1-10) or pulses per revolution (P1-08 and P1-09).
- (4) Select the external position command pulse input format. For example, if using pulse + direction, set P1-02 = 0.
- (5) Turn on the main circuit power.
- (6) After confirming there are no abnormalities or alarms, set the input control signal (SON) to the ON state. The motor will then be energized and remain at zero speed.
- (7) Operate the position pulse signal output to pins CN2\_42, CN2\_43, CN2\_14, and CN2\_15 to make the motor run according to the command.
- (8) If the motor's rotation direction is opposite to the required direction, set P1-01 to 1 (reverse direction).
- (9) In the monitoring state, Fn-01 and Fn-02 can display the current pulse value from the encoder feedback; Fn-03 and Fn-04 can display the position command pulse input value from the host controller.

## 7.4 Speed Control

### 7.4.1 Speed arriving signal

When the motor's operating speed reaches the set speed detection threshold, the servo outputs the SSPD signal.

#### ■ Related Parameters

P	Function Code	Method	Range	Default Value	UNIT	Communication ADD (Decimal)
5	P1-2 When the motor speed exceeds this set speed, the SSPD signal outputs ON.	S	-6000~6000	100	Rp m	4x281

### 7.4.2 Speed Selection

P1-00 set	SPD2	SPD1	Speed value
2	OFF	OFF	0
	OFF	ON	P4-44
	ON	OFF	P4-45
	ON	ON	P4-46

### 7.4.3 ACC/DEC Time

P	Function Code	Method	Range	Default Value	UNIT	Communication ADD (Decimal)
6	P2-2 Speed control ACC time	S T	0~1000	30	m s	4x538
7	P2-2 Speed control DEC time	S T	0~1000	30	m s	4x539

### 7.4.4 Operation Procedure

- (1) Connect to CN2, ensuring the input control signal (SON) is in the OFF state.
- (2) Turn on the control circuit power (do not connect the main circuit power yet). The drive unit's display should light up, showing "r - 0" if there are no alarms. If an alarm appears, identify the cause and resolve it until no alarms are present.
- (3) Set the control mode selection parameter P1-00 to 2.
- (5) Turn on the main circuit power.
- (6) Select different internal speed reference parameter values through the DI input pins.
- (7) After confirming there are no abnormalities or alarms, set the input control signal (SON) to the ON state. The motor

will then run at the selected set speed.

## 7.5 Torque Control

### 7.5.1 Torque Arriving Signal

When the motor's operating torque reaches the set torque detection threshold, the servo performs filtering based on the time set in P2-85. If the real-time torque still remains greater than or equal to the torque detection threshold after exceeding the filtering time set in P2-85, the servo outputs the TSPD signal.

After the torque is reached, the servo allows a torque arrival lower limit. As long as the

real-time torque is greater than this lower limit, it is considered that the torque has been reached, and the TSPD signal will remain output. Once the real-time torque falls below the torque arrival lower limit, the TSPD signal will turn off, and the system will re-enter the next detection cycle. The TSPD signal will only output again when the real-time torque reaches the set torque detection threshold in the next cycle.

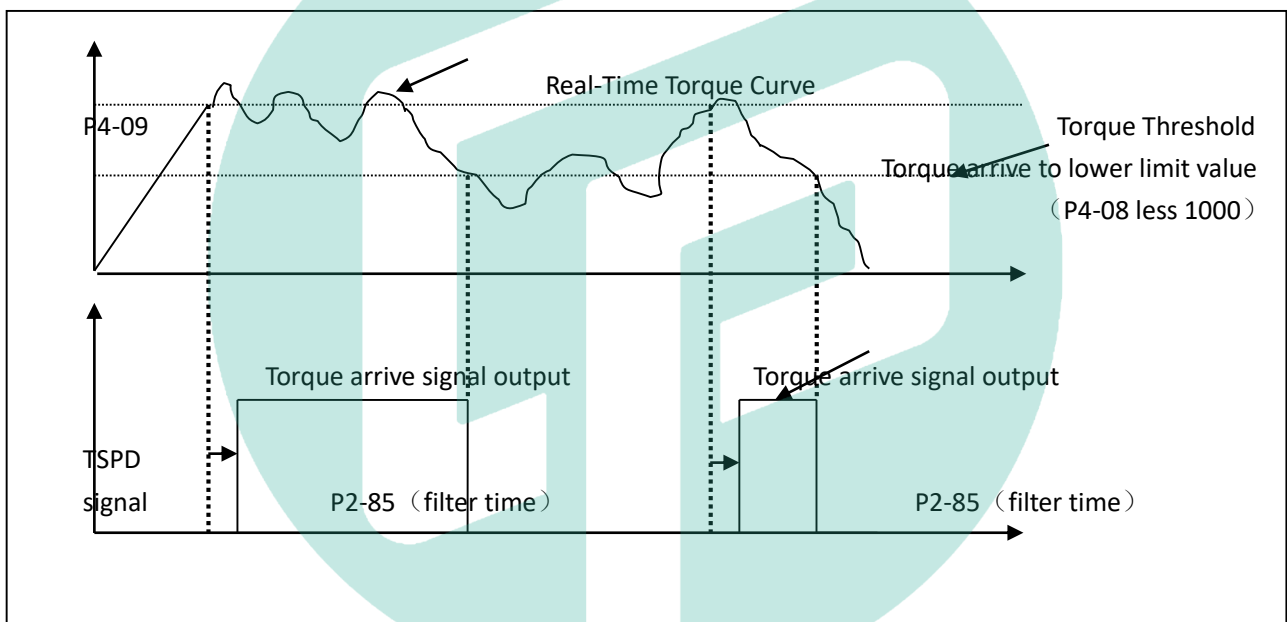

### 7.5.2 Torque Threshold selection

P1-00 set	P1-19	FIL	RIL	Torque threshold
4	0	OFF	OFF	P4-09
		ON	OFF	P4-10
		OFF	ON	P4-11
		ON	ON	No check
	1	Feedback speed > 0		P4-09
		Feedback speed ≤ 0		P4-10

Note: The operating speed is set by parameter P4-44.

### 7.5.3 Speed Selection

P1-00 set	P1-03	SPD2	SPD1	Torque threshold
-----------	-------	------	------	------------------

4	0	OFF	OFF	P4-44
		ON	OFF	P4-45
		OFF	ON	P4-46
		ON	ON	P4-47
	1	The speed is controlled by the external pulse frequency		

## 7.5.4 Related Parameters

P	Function Code	Method	Range	Default Value	UNIT	Communication ADD (Decimal)
P1-19	Torque Output Limit Switch	T	0~1	0	/	4x275
P2-26	Speed Control Acceleration Time	S T	0~10000	300	ms	4x538
P2-27	Speed Control Deceleration Time	S T	0~10000	300	ms	4x539
P4-08	Torque Arrival Lower Limit Coefficient	T	0~1000	1000	%	4x1032
P4-09	Internal Torque Command 1 / Internal Torque Limit 1	T	0~500	15	%	4x1033
P4-10	Internal Torque Command 2 / Internal Torque Limit 2	T	0~500	20	%	4x1034
P4-11	Internal Torque Command 3 / Internal Torque Limit 3	T	0~500	20	%	4x1035
P4-44	Internal Speed Control Reference 1	S	-6000~6000	100	rpm	4x1068
P4-45	Internal Speed Control Reference 2	S	-6000~6000	200	rpm	4x1068
P4-46	Internal Speed Control Reference 3	S	-6000~6000	300	rpm	4x1068
P4-47	Internal Speed Control Reference 4	S	-6000~6000	500	rpm	4x1068

## 7.6 Absolute Value System

### 7.6.1 Motor Zeroing

When the motor factory adapts the LC-500G system development platform for delivery, a zeroing operation must be performed. Ensure the motor is in a no-load state during zeroing; otherwise, inaccurate zeroing may lead to poor control performance or servo alarm abnormalities. The specific steps are as follows:

- (1) Set P1-00 to 14.
- (2) Set P0-02 to 2.

After completing the settings, the motor's rotating shaft will automatically align to a specific point, and the servo system will reset and restart automatically. Once zeroing is completed, the host controller can control the servo normally.

### 7.6.2 Power Loss and Low Voltage Exception Handling

#### 7.6.2.1 Usage Conditions

- (1) Use the multi-turn position data memory function.

(2) The battery is a 3.6V dry battery.

### 7.6.2.2 Related Parameters

Parameter	Function Code	method	Range	default value	UNIT	Communication ADD (Decimal)
P2-39	Absolute Encoder Multi-Turn Data Switch - 0: Single-Turn Memory – No battery required. - 1: Multi-Turn Memory – A battery must be used.	P S T	0~6	0	/	4x551

### 7.7.2.3 Alarm Explanation

Parameter setting	Battery power off ( $2.5 \pm 0.2V$ )	Battery low voltage ( $3.1 \pm 0.1V$ )	Solving process
P2-39 = 0	No alarm	No abnormalities. You can configure the DO1 output signal as a low battery alarm output signal. When the battery voltage is low, the host controller can detect this signal to determine whether the battery is in a low-voltage state.	
P2-39 = 1	ALE-8 (No. 8 alarm)	There is no alarm code, but the decimal point on the lowest digit of the digital display is blinking	<ol style="list-style-type: none"> <li>1. Replace the battery to ensure the battery voltage is 3.6V.</li> <li>2. After replacing the battery, set parameter P0-03 to 1 and reset the system development platform.</li> <li>3. Power on again, and the alarm will be cleared, allowing normal operation.</li> <li>4. Once a battery alarm occurs and the servo is reset, the multi-turn position data will be reset to 0. The original coordinates in</li> </ol>

			the host controller system will change, and the coordinate origin needs to be redefined.
--	--	--	--

**Note:** When a low battery warning appears, the encoder position can still be memorized, and the system can continue to operate normally. The host controller does not need to reset the coordinate origin, but it is important to monitor the battery level and replace the battery in a timely manner.

### 7.6.3 Reading 32-bit Packed Position Data via Communication

The absolute encoder position data is 32 bits, represented by four bytes, which are stored in four internal register addresses of the servo. The host controller can obtain the 32-bit position data through MODBUS RTU communication. Before reading the 32-bit data, set P2-39 to 1 (enable multi-turn data reading).

ADD (Decimal)	Data type	备注
1309	32-bit Integer	The encoder position data, after being packed, has already incorporated the electronic gear ratio into the calculation

### 7.6.4 Multi-Turn Zeroing

After setting P2-57 to 4, the servo will automatically clear the multi-turn data of the encoder and reset itself. Note that when this parameter is set to 4, the setting will not be saved.

■ Related Parameters

Parameter	Function Code	method	Range	default value	UNIT	Communication ADD (Decimal)
P2-57	Absolute Encoder Control Commands 1: Read Single-Turn Data 2: Read Multi-Turn Data 3: Clear Single-Turn Data 4: Clear Multi-Turn Data 5: Alarm Reset	P S T	1~5	2	/	4x569

### 7.6.5 Servo Internal Homing

#### 7.7.5.1 Homing Characteristics

The AIC-M680X-SH-Kit servo development platform can independently perform various homing functions. After homing is completed, it automatically sends a completion signal to the host computer. The homing function of the AIC-M680X-SH-Kit servo development platform has the following characteristics:

① Homing is simple and convenient, with high repeatability and accuracy. It does not require host computer intervention, simplifying the homing operation on the host computer.

② The homing operation can only be performed after the servo is enabled.

③ The homing operation has the highest priority. As long as the homing conditions are met, the servo motor will immediately execute the homing operation. After power-on, multiple homing operations can be performed.

④ When P1-28 is set to 1, the servo can automatically perform the homing operation after power-on. After homing is completed, it automatically enters the control mode set by P1-00.

⑤ The homing completion signal has a fixed width of 100ms.

### 7.7.5.2 Coordinate Origin Setting

When using the servo system for homing, the coordinate origin needs to be preset. The AIC-M680X-SH-Kit provides two methods for setting the coordinate origin:

(1) Set P1-28 to 2, and the system will automatically set the current position as the coordinate origin.

(2) Define the IO input pin as the SetAxis function. An external low-level trigger signal to this pin can also designate the current position as the coordinate origin.

#### ■ Related Parameters

Parameter	Function Code	method	Range	default value	UNIT	Communication ADD (Decimal)
P1-28	Automatic Homing Mode Switch: 0: After the servo receives the enable signal, an external I/O trigger is required to initiate homing. 1: After the servo receives the enable signal, it automatically starts homing. 2: Set the origin position. The current position of the absolute encoder is directly used as the origin. This setting is invalid for incremental encoders.	P S T	0~2	0	/	4x284

### 7.7.5.3 Home Mode

P 1-29	Homing Method Definitions	Home process Description
0	Absolute Coordinate Homing	① Set the coordinate origin position ② When P1-28 is set to 1 or the I/O input pin is configured as SHOME and is active, the servo motor will firstly return to HOME at the speed (high speed) set by P1-30

4	Single DOG Rising Edge + DOG Falling Edge	<p>① When P1-28 is set to 1 or the I/O input pin is configured as SHOME and is active, the servo motor will firstly return to HOME at the speed (high speed) set by P1-30</p> <p>② When the I/O input pin is configured as ORG1 and changes from OFF to ON, the motor will run in reverse at the speed set by P1-31.</p> <p>③ When the I/O input pin is configured as ORG1 and changes from ON to OFF, the motor will stop running, and homing is completed.</p> <p>④ When the DO1 pin is configured as the homing completion signal, it will output the homing completion signal</p>
5	Single DOG Rising Edge + DOG Falling Edge + Offset	<p>① When P1-28 is set to 1 or the I/O input pin is configured as SHOME and is active, the servo motor will firstly return to HOME at the speed (high speed) set by P1-30</p> <p>② When the I/O input pin is configured as ORG1 and changes from OFF to ON, the motor will run in reverse at the speed set by P1-31</p> <p>③ When the I/O input pin is configured as ORG1 and changes from ON to OFF, the motor will stop running</p> <p>④ After motor stop in stable, Set speed by P1-32, operate a offset, <math>OFFSET = (P1-33) \times 10000 + (P1-32)</math></p> <p>⑤ When the DO1 pin is configured as the homing completion signal, it will output the homing completion signal</p>
10	DOG Detection (Trigger level)	<p>① When P1-28 is set to 1 or the I/O input pin is configured as SHOME and is active, the servo motor will firstly return to HOME at the speed (high speed) set by P1-30</p> <p>② When the I/O input pin is configured as ORG1 and is active, the motor will stop, homing is completed, and the homing completion signal is output. The system will automatically enter the control mode set by P1-00</p>
11	DOG Detection (Rising edge)	<p>① When P1-28 is set to 1 or the I/O input pin is configured as SHOME and is active, the servo motor will firstly return to HOME at the speed (high speed) set by P1-30</p> <p>② When the I/O input pin is configured as ORG1 and changes from OFF to ON, the motor will stop, homing is completed, and the homing completion signal is output. The system will automatically enter the control mode set by P1-00</p>
12	DOG Detection + torque	<p>① When P1-28 is set to 1 or the I/O input pin is configured as SHOME and is active, the servo motor will firstly return to HOME at the speed (high speed) set by P1-30</p> <p>② When the torque output by the servo motor is greater than or equal to the value set by P4-09, the servo will begin searching for the Z pulse at the speed set by P1-31 (low speed)</p> <p>③ Once the Z pulse is detected, the servo motor will stop running, and homing is completed</p>

		④ The homing completion signal is output, and the system will automatically enter the control mode set by P1-00
--	--	---

## 7.7 Auxiliary functions

### 7.7.1 I/O input pin function configuration

Set Parameter	Name	Function Explanation	Function Code	Trigger Mode	Operate Mode
1	SON	Servo Start	<b>OFF:</b> Servo motor enable is disabled. <b>ON:</b> Servo motor is powered and enabled	Level Trigger	P S T
2	ALRS	Alarm Reset Signal	Faults can be divided into resettable faults and non-resettable faults. This function is used to clear alarms or reset the system after troubleshooting.	Edge Trigger	P S T
3	SHOLD	Internal Speed Command Pause	During internal speed operation, when this signal is active, the servo motor decelerates and stops.	Level Trigger	S
4	P-OT	Forward Drive Disable	When mechanical movement exceeds the allowable range, the over-travel prevention function is activated. <b>ON:</b> Forward drive is disabled. <b>OFF:</b> Forward drive is allowed	Level Trigger	P S T
5	N-OT	Reverse Drive Disable	When mechanical movement exceeds the allowable range, the over-travel prevention function is activated. <b>ON:</b> Reverse drive is disabled. <b>OFF:</b> Reverse drive is allowed.	Level Trigger	P S T
6	RIL	Forward External Torque Limit	① When RIL=ON and FIL=OFF, forward external torque limit is applied. ② When RIL=OFF and FIL=ON, reverse external torque limit is applied. ③ In other cases, both forward and reverse are subject to external torque limits	Level Trigger	P S T
7	FIL	Reverse External		Level Trigger	P S T

		Torque Limit			
8	PCLR	Pulse Error Clear	<p><b>ON:</b> Clears the residual pulses in the system development platform, and the servo stops immediately.</p> <p><b>OFF:</b> The servo stops automatically after running the residual command pulses</p>	- Edge/Level Trigger	P
9	LOK	Zero Speed Clamp	<p><b>ON:</b> Zero speed clamp, no speed analog voltage is accepted, and the motor remains at zero speed.</p> <p><b>OFF:</b> Accepts external analog voltage, and the speed operates according to the given voltage command</p>	Level Trigger	S T
10	SPD1	Internal Speed Selection 1	Used for multi-speed switching function	Level Trigger	S T
11	SPD2	Internal Speed Selection 2			
13	MDC	Control Mode Switch	Used for hybrid mode switching	Level Trigger	P S T
14	INH	Position Command Disable	<p><b>ON:</b> Allows external command pulse input.</p> <p><b>OFF:</b> Disables external command pulse input</p>	Level Trigger	Pt
15	SPDIN V	Speed Command Direction Inversion	<p><b>ON:</b> Command direction is inverted.</p> <p><b>OFF:</b> Default command direction</p>	Level Trigger	S T
16	G-SEL	Speed Gain Switch	<p><b>ON:</b> Speed gain switching (refer to P2-09 for the switching coefficient).</p> <p><b>OFF:</b> System default control</p>	Level Trigger	P S T
21	SHOME	Start Homing	Triggers servo homing.	Edge Trigger	P S T
22	ORG1	Proximity Switch Signal 1	During servo homing, when ORG1 is active, the servo begins to decelerate or stop	Edge/Level Trigger	P S T
23	ORG1	Proximity Switch Signal 2	During servo homing, when ORG1 is active, the servo begins to decelerate or stop	Edge/Level Trigger	P S T
24	POS1	Internal Speed Selection 1	Used for multi-position switching function. The AIC-M680X-SH-Kit currently supports only 8 position segments. For more segments, customization by the manufacturer is required	Level Trigger	Pr
25	POS2	Internal Speed Selection 2			
26	POS3	Internal Speed Selection 3			
27	POS4	Internal Speed Selection 4			

		Selection 3			
28	TTRIN V	Torque Command Inversion	<b>ON:</b> Command direction is inverted <b>OFF:</b> Default command direction	Level Trigger	T
31	EMC	Emergency Stop	<b>ON:</b> Emergency stop <b>OFF:</b> Continue operation	Level Trigger	P S T
40	SetAx is	Coordinate Origin Setting		Edge Trigger	P S T

## 7.7.2 I/O output pin function configuration

Set Paramet er	Name	Function Explanation	Function Code	Trigger Mode	Operate Mode
1	SRDY	Servo Ready	Servo Ready Output Signal	Open-collector level output	P S T
2	ALARM	Servo Alarm	Servo Alarm Output Signal	Open-collector level output	P S T
3	ZSPD	Position Reached	Positioning Completion Signal	Open-collector level output	P
4	SSPD	Speed Reached	Speed Reached Output Signal	Open-collector level output	S
5	TSPD	Torque Reached	Torque Reached Output Signal	Open-collector level output	T
6	BRKR	Motor Brake	Motor Brake Output Control Signal	Open-collector level output	P S T
7	HOME	Homing Completed	At Origin Output Signal	Open-collector level output	P S T
8	CZ	Z Pulse	CZ Output Signal	Open-collector level output	P S T
9	Battery Low	Low Battery Voltage	Low Battery Voltage Alarm Output Signal	Open-collector level output	P S T

## 7.7.3 Anti-Blocking Protection

When the servo is blocked or stalled, the current will suddenly increase, but it may not trigger an over-current or module alarm. If this condition persists for a long time, it will inevitably cause the motor to overheat. To avoid this issue, the AIC-M680X-SH-Kit is equipped with an anti-blocking protection function.

### ■ Related Parameters

Parameter	Function Code	method	Range	default	UNIT	Communication
-----------	---------------	--------	-------	---------	------	---------------

نشانی: تهران - خیابان سعدی جنوبی - چهارراه اکباتان ناظم الاطبا شمالی - پلاک ۱۶۷

تلفن: ۰۲۶۰۳۳۵۳۲۶ - ۰۲۶۰۳۳۵۳۲۶ - ۰۲۶۰۳۳۵۳۲۱۹۴ - ۰۲۶۰۳۳۹۵۹۷۵۶ - ۰۲۶۰۳۳۹۵۹۷۵۶ - ۰۲۶۰۳۶۶۱۹۵۱۰ - ۰۲۶۰۳۶۶۱۹۳۹۰

<https://shop.cncparts.ir>

				value		ADD (Decimal)
P1-62	Motor Running Overload Ratio 1	P S T	0~500	120	%	4x318
P1-63	Overload Alarm Delay Time 1	P S T	0~30000	6000	S	4x319

Note: The value set in P1-62 must not exceed the value set in P1-59.

## 7.7.4 Current Output Limit

Parameter	Function Code	method	Range	default value	UNIT	Communication ADD (Decimal)
P2-53	Current output limit	P S T	0~1000	500	0.001	4x565

Note: The actual current output = (P2-53 / 1000) \* (Module's peak current) / 1.414.

## 7.8 Test Operation

### 7.8.1 Operation Procedure

- (1) Set parameter P1-00 = 13 to enable the servo to operate in test run mode.
- (2) Set parameter P1-04 = 1 to enable the internal servo.
- (3) Access parameter P4-01 and modify its value to set the speed command.
- (4) After modification, press the "SET" key to confirm. The servo will then operate according to the value set in P4-01. A positive value indicates forward rotation, while a negative value indicates reverse rotation.

## Chapter 8: Alarms and Handling

### 8.1 Alarm List

Alarm Warning	Alarm name	Content
--	Normal	
ALE 01	Overs-peed Alarm	Servo motor speed exceeds the set value
ALE 02	Main Circuit Over-voltage	Main circuit power supply voltage is too high
ALE 03	Main Circuit Under-voltage	Main circuit power supply voltage is too low

ALE 04	Position Deviation Alarm	The value of the position deviation counter exceeds
ALE 05	Encoder Overheat Alarm	Encoder temperature is too high
ALE 06	Speed Amplifier Saturation	Speed regulator is saturated for a long time.
ALE 07	Drive Disable Abnormality	Both CCW and CW drive disable inputs are OFF
ALE 08	Encoder Power Loss Alarm	Multi-turn absolute encoder battery voltage is too
ALE 09	Encoder Feedback Signal Error	Encoder feedback data or signal is incorrect
ALE 10	Control Power Under-voltage	Control power supply is too low
ALE 11	IPM Module Fault	IPM intelligent module fault
ALE 12	Over-current	Motor current is too high
ALE 13	Over-load	System development platform and motor are overloaded
ALE 14	Brake Fault	Brake circuit fault
ALE 15	Motor Pole Pair Error Alarm	Motor pole pairs do not match the corresponding motor
ALE 16	Main Power Supply Loss Alarm	Main circuit power is not supplied
ALE 17	Reserved	- Reserved
ALE 18	Invalid Motor Model	Motor model is not written into the incremental
ALE 19	Encoder Disconnection Alarm	Encoder cable is not connected or is broken
ALE 20	EEPROM Error	EEPROM error
ALE 21	Serial Communication Error	RS232 or RS485 communication error
ALE 22	Current Sampling Circuit Alarm	Current sampling power input is incorrect
ALE 23	Motor Power Line Phase	Motor UVW wiring is incorrect or there is a phase loss
ALE 25	Z Signal Loss Alarm	The driver does not detect the encoder Z signal
ALE 26	CPLD Data Bus Error	DSP and CPLD data transmission error
ALE 27	Module Temperature Alarm	Module temperature overheating alarm
ALE 32	Overload Alarm	Motor continuous output exceeds the rated load

## 8.2 Alarm Solving Method

ALM Code	Alarm Name	Operate state	Reason	Solve Method
ALE01	Over-Speed	- Occurs when the control power is turned on.	① Control circuit board fault. ② Encoder fault.	① Replace the system development platform. ② Replace the servo motor. ◦
		Occurs during motor operation.	Over-speed alarm threshold is set too low.	Increase the value of parameter P1-16.
			Input command pulse frequency is too high.	Set the input command pulse correctly

نشانی: تهران - خیابان سعدی جنوبی - چهارراه اکباتان ناظم الاطبا شمالی - پلاک ۱۶۷

تلفن: ۰۳۶۶۱۹۳۹۰ - ۰۳۶۶۱۹۵۱۰ - ۳۳۹۵۹۷۵۶ - ۳۳۹۵۹۷۵۶ - ۳۳۵۳۲۱۹۴ - ۳۳۹۵۹۳۲۶ - ۳۳۵۳۲۶۰۲

<https://shop.cncparts.ir>

			Acceleration/deceleration time constant is too small, causing excessive speed overshoot	Increase the acceleration/deceleration time constant.
			Input electronic gear ratio is too large	Set it correctly.
			Encoder fault	Replace the servo motor.
			Encoder cable is faulty.	Replace the encoder cable.
			Servo system is unstable, causing overshoot	① Reconfigure the relevant gains. ② If the gains cannot be set to appropriate values, reduce the load inertia ratio
			Load inertia is too large	① Reduce the load inertia. ② Replace with a higher-power drive and motor.
			Encoder zero point error	① Replace the servo motor. ② Request the manufacturer to recalibrate the encoder zero point
			① The motor U, V, W leads are connected incorrectly. ② The encoder cable leads are connected incorrectly.	Wiring correctly
ALE02	Main circuit over-voltage.	Occurs when the control power is turned on	Main-circuit problem	Replace the system development platform unit.
		Occurs when the main power is turned on.	① Power supply voltage is too high ② Power supply voltage waveform is abnormal	Check the power supply.
		Occurs during motor operation	brake resistor wiring cut off	Reconnect the wiring
		Occurs during motor operation	① Braking transistor is damaged. ② Internal braking resistor is damaged	Replace the system development platform unit

			Brake Circuit back capacity lack	<ul style="list-style-type: none"> <li>① Reduce the start/stop frequency.</li> <li>② Increase the acceleration/deceleration time constant.</li> <li>③ Decrease the torque limit value.</li> <li>④ Reduce the load inertia.</li> <li>⑤ Replace with a higher-power drive and motor.</li> </ul>
ALE03	Main circuit under-voltage.	Occurs when the main power is turned on	<ul style="list-style-type: none"> <li>① Circuit board fault.</li> <li>② Power supply fuse is damaged.</li> <li>③ Soft-start circuit fault.</li> <li>④ Rectifier is damaged.</li> </ul>	Replace the system development platform drive unit
			<ul style="list-style-type: none"> <li>① Power supply voltage is too low.</li> <li>② Temporary power outage for more than 20ms</li> </ul>	Check the power supply.
		Occurs during motor operation	<ul style="list-style-type: none"> <li>① Power supply capacity is insufficient</li> <li>② Instantaneous power loss</li> <li>③ IPM module short circuit</li> </ul>	Check the power supply and IPM module.
			Heat sink over-heat	Check the load condition.
ALE04	Position Deviation	Occurs when the control power is turned on	Circuit problem	Replace the system development platform.
		Occurs when the main power and control lines are connected, and command pulses are input, but the motor does not rotate	<ul style="list-style-type: none"> <li>① The motor U, V, W leads are connected incorrectly.</li> <li>② The encoder cable leads are connected incorrectly</li> </ul>	Connect the wiring correctly.
			- Encoder fault.	Replace the servo motor.
			- Position deviation detection range is set too small.	Increase the position deviation detection range.
- Position proportional gain is too	- Increase the gain.			

			small.	
			Lack of torque	<ol style="list-style-type: none"> <li>① Check the torque limit value.</li> <li>② Reduce the load capacity.</li> <li>③ Replace with a higher-power drive unit and motor</li> </ol>
			Command pulse frequency is too high	Low down frequency
ALE05	Encoder Overheat	Occurs when the control power is turned on	Circuit board fault	Replace the system development platform drive unit
			<ol style="list-style-type: none"> <li>① Cable breakage.</li> <li>② Internal temperature relay in the motor is damaged</li> </ol>	<ol style="list-style-type: none"> <li>① check the cable</li> <li>② check the servo motor</li> </ol>
	Occurs during motor operation	Motor over-load lead to full heat	<ol style="list-style-type: none"> <li>① Reduce the load.</li> <li>② Lower the start/stop frequency.</li> <li>③ Decrease the torque limit value.</li> <li>④ Reduce the relevant gains.</li> <li>⑤ Replace with a higher-power drive unit and motor.</li> </ol>	
		encoder internal problem	① change servo motor	
ALE06	Speed Amplifier Saturation Fault	Occurs during motor operation	motor is stuck by mechanical	check the mechanical load part
			load is so heavy	<ol style="list-style-type: none"> <li>① reduce load</li> <li>② Change a big power drive motor</li> </ol>
ALE07	Drive Disable Abnormality		Both CCW and CW drive disable input terminals are disconnected	Check power of the wiring and input terminal

ALE08	Encoder Power Loss Alarm		<ul style="list-style-type: none"> <li>① Motor encoder is damaged.</li> <li>② The battery has no power.</li> <li>③ Encoder cable is faulty.</li> </ul>	<ul style="list-style-type: none"> <li>① Replace the battery.</li> <li>② Check if the encoder cable is damaged.</li> <li>③ Replace the drive unit.</li> </ul>
ALE09	Encoder Feedback Signal Error		Encoder wiring wrong	Check wiring
			Encoder is damaged	Change motor
			Encoder cable is bad	Change encoder cable
ALE09	Encoder Communication Error		Encoder cable is too long, cause the supply voltage for encoder is lower	<ul style="list-style-type: none"> <li>① short encoder cable</li> <li>② Use multi-core parallel power supply.</li> </ul>
ALE 10	Control Power Under-voltage		Input control power is lower	check the control power
			<ul style="list-style-type: none"> <li>① Poor internal connector in the drive.</li> <li>② Switching power supply abnormality.</li> <li>③ Chip damage.</li> </ul>	<ul style="list-style-type: none"> <li>① Replace the drive unit.</li> <li>② Check the connectors.</li> <li>③ Inspect the switching power supply.</li> </ul>
ALE 11	IPM Module Fault	Occurs when the control power is turned on	Circuit problem	Replace the system development platform unit.
		Occurs during motor operation	<ul style="list-style-type: none"> <li>① power supply voltage is lower</li> <li>② over-heat</li> </ul>	<ul style="list-style-type: none"> <li>① Inspect the drive unit.</li> <li>② Power on again.</li> <li>③ Replace the drive unit.</li> </ul>
			Short circuit between drive U, V, and W phases	Check wiring
			Poor grounding	ground correctly
		motor insulation	Change the motor	

			damaged	
			Subject to interference	<ol style="list-style-type: none"> <li>① Add a line filter.</li> <li>② Stay away from the interference source.</li> </ol>
ALE 12	Over-current		Short circuit between drive U, V, and W phases	Check wiring
			Poor ground	correctly ground
			Motor insulation damaged	Change motor
			Driver damaged	Change servo drive unit
ALE13	Over-load	Occurs when the control power is turned on	Circuit problem	Change system developing platform
		Occurs during motor operation	Over rated torque operation	<ol style="list-style-type: none"> <li>① Check the load.</li> <li>② Reduce the start/stop frequency.</li> <li>③ Decrease the torque limit value.</li> <li>④ Replace with a higher-power drive unit and motor.</li> </ol>
			Hold brake not open	Check holding brake
			Motor unstable vibration	<ol style="list-style-type: none"> <li>① Adjust the gain.</li> <li>② Increase the acceleration/deceleration time.</li> <li>③ Reduce the load inertia.</li> </ol>
			<ol style="list-style-type: none"> <li>① One phase of U, V, or W is disconnected.</li> <li>② Encoder wiring error.</li> </ol>	Check wiring
ALE 14	Brake Fault	Occurs when the control power is turned on	Circuit board fault	- Replace the system development platform unit.
		Occurs during motor operation	Braking resistor wiring is disconnected	- Reconnect the wiring.
			<ol style="list-style-type: none"> <li>① Braking transistor is damaged.</li> <li>② Internal braking resistor is damaged</li> </ol>	- Replace the system development platform unit.
ALE 14	Brake Fault	Occurs during motor operation	Braking circuit capacity is insufficient	<ol style="list-style-type: none"> <li>① Reduce the start/stop frequency.</li> <li>② Increase the acceleration/deceleration time</li> </ol>

				constant. ③ Decrease the torque limit value. ④ Reduce the load inertia. ⑤ Replace with a higher-power drive unit and motor.
			Main circuit power supply voltage is too high	Check main power
ALE 15	Motor Pole Pair Error	Occurs when the motor is powered on or during operation	Motor pole pairs do not match the corresponding motor	Reconfigure the correct pole pairs for the corresponding motor, then power on again.
ALE 16	Main Power Supply Loss Alarm		Main circuit is not powered	Check the main power supply.
			Main circuit over-voltage.	Check the main power supply.
			Main circuit under-voltage	Check the main power supply.
ALE 18	Invalid Motor Model		Motor model is not written into the incremental encoder's EEPROM	The incremental encoder was not programmed with the motor model or was programmed with a motor model of 0 during motor production.
ALE 19	Encoder Disconnection Alarm		Encoder cable is not connected or is damaged	Connect the encoder cable; replace the encoder cable.
ALE 20	EEPROM Error		Chip or circuit board is damaged	Replace the system development platform unit.
ALE 21	Serial Communication Error Alarm		RS232 or RS485 communication error	① Check if the communication line is intact. ② Verify if the communication data format is correct.
ALE 22	Current Sampling Circuit Alarm		Current sampling circuit power input is incorrect	① Check if the input power is within the specified range. ② Inspect the amplification circuit for any abnormalities
ALE23	Phase Sequence Error	Occurs during the drive enable process	① Motor power line phase sequence is incorrect. ② Motor power line has	① Replace the motor. ② Replace the power cable. ③ Verify if the power cable is connected correctly.

	Alarm-		a phase loss. ③ Motor abnormality.	
ALE27	- Module Temperature Alarm	Occurs during motor operation	① Poor internal wiring in the drive. ② Module temperature is too high	① Replace the drive unit. ② Reduce the motor operating load. ③ Reduce the motor operating speed.
ALE32	Over-load	Occurs when the control power is turned on	Circuit board fault	Replace the system development platform
		Occurs during motor operation	Operating beyond rated torque	① Check the load. ② Reduce the start/stop frequency. ① Decrease the torque limit value. ② Replace with a higher-power drive unit and motor.
			Holding brake is not released	Check the holding brake
			Motor is unstable or oscillating	① Adjust the gain. ② Increase the acceleration/deceleration time. ③ Reduce the load inertia

# CNC PARTS

## Chapter 9 MODBUS RTU Communication Instructions

### 9.1 Scope of Application

The ES750 servo drive supports the MODBUS RTU protocol and can use RS485 communication, featuring a "single-master,

۴۵

نشانی: تهران - خیابان سعدی جنوبی - چهارراه اکباتان ناظم الاطبا شمالی - پلاک ۱۶۷

تلفن: ۰۲۰۳۳۵۳۲۶ - ۳۳۹۵۹۳۲۶ - ۳۳۵۳۲۱۹۴ - ۳۳۹۵۹۷۵۶ - ۳۳۹۵۹۷۵۶ - ۳۶۶۱۹۵۱۰ - ۳۶۶۱۹۳۹۰

<https://shop.cncparts.ir>

multiple-slave" communication network. Before using the communication function, each drive must configure the communication parameters (station number P3-00, baud rate P3-01, data format P3-02). Through the communication function, the host computer can directly modify the internal parameters of the drive and read the servo operation status, among other tasks.

## 9.2 Protocol Format

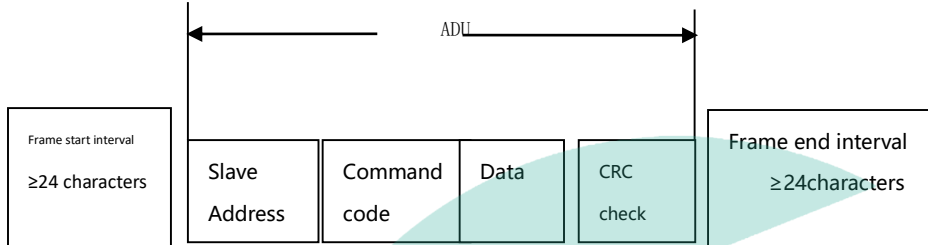

The protocol format is as shown in the figure above. The checksum in the ADU is derived from the CRC16 checksum of the preceding part of the ADU, with the high and low bytes swapped. In the protocol format, the low byte of the CRC comes first, followed by the high byte.

1、 Read the system development platform function code parameters or status words (command code 0x03)

ADU partial content	Byte	Range
Master send demand:		
Slave address	1	1-0xFEH
Command code	1	0x03H
register start address	2	0x0000H-0xFFFFH
Register numbers	2	0x0000H-0x0008H
CRC check (low byte in front)	2	
Slave Response:		
Slave address	1	Local address
Command code	1	0x03H
Read byte numbers	1	0x02H
Register content	2	Register content
CRC check	2	

Example: Read Parameter P1-06 value is 1

Master send: 0x01 0x03 0x01 0x06 0x00 0x01 0x65 0xf7

Slave Return: 0x01 0x03 0x020x00 0x01 0x79 0x84

2、 Write a single function code or control parameter to the system development platform. (command code 0x06)

ADU partial content	Byte	Range
Master send demand:		
Slave address	1	1-0xFEH
Command code	1	0x06H
register start address	2	0x0000H-0xFFFFH
Register numbers	2	0x0000H-0x0008H
CRC check (low byte in front)	2	
Slave Response:		
Slave address	1	Local address
Command code	1	0x03H
Read byte numbers	2	0x0000H-0xFFFFH
Register content	2	Register content
CRC check	2	

For example, write the value 10 into parameter P1-06.

Master Send: 0x01 0x06 0x01 0x05 0x00 0x0A 0x36 0xC2

Slave Return: 0x01 0x06 0x01 0x05 0x00 0x0A 0x69 0xFB

3、 Write a single function code or control parameter to the system development platform (command code 0x10)

ADU partial content	Byte	Range
Master send request:		
Slave address	1	1-0xFEH
Command code	1	0x10H
register start address	2	0x0000-0xFFFF
Register numbers	1	0x0000-0x0008
CRC check (low byte in	2*register	

front )	numbers	
Slave address	2	
Slave response:		
Slave address	1	Local address
Command code	1	0x10
Register start address	2	0x0000-0xFFFF
ADU partial content	byte	Range
Register numbers	2	0x0000-0x0008
CRC check	2	

### 9.3 CRC Check

The sending device first calculates the CRC value and appends it to the transmitted message. Upon receiving the message, the receiving device recalculates the CRC value and compares it with the received CRC value. If the two values do not match, it indicates that an error occurred during transmission.

CRC Calculation Process:

1. Define a CRC register and initialize it with a value of 0xFFFF.
2. Perform an XOR operation between the first byte of the transmitted message and the value in the CRC register, then store the result in the CRC register. The calculation starts from the address code, and the start and stop bits are not included.
3. Extract and check the LSB (Least Significant Bit) of the CRC register.
4. Shift all bits in the CRC register to the right by one position, filling the highest bit with 0.
5. If the LSB is 1, perform an XOR operation between the CRC register value and A001H, and store the result in the CRC register.
6. Repeat steps 3, 4, and 5 until 8 shifts are completed.
7. Repeat steps 2, 3, 4, 5, and 6 to process the next byte of the transmitted message. Continue this process until all bytes of the transmitted message are processed.
8. After the calculation is complete, the content of the CRC register is the CRC check value.
9. During transmission, send the low byte of the CRC check value first, followed by the high byte.

## Chapter 10: Appendix

## 10.1 Motor model code comparison table

### 10.1.1 Five pole pairs motor model code

Model code	Matched Motor	Motor Frame size	Voltage	Rated Power	Rated Current	Rated Torque	Rated Speed	Pairs	Driver Model
100		40mm	220V	100W	1.1A	0.32N.m	3000rpm	5	
101		60mm	220V	200W	1.6A	0.64N.m	3000rpm	5	
102		60mm	220V	400W	2.6A	1.27N.m	3000rpm	5	
103		80mm	220V	750W	4.6A	2.39N.m	3000rpm	5	
104		80mm	220V	1.0KW	5.7A	3.18N.m	3000rpm	5	
109		130mm	220V	1.0KW	6.9A	5.39N.m	1500rpm	5	

### 10.1.2 Four pole pairs motor model code

Model code	Matched Motor	Motor Frame size	Voltage	Rated Power	Rated Current	Rated Torque	Rated Speed	Pairs	Driver Model
2		60mm	220V	400W	2.8A	1.27N.m	3000rpm	4	
5		80mm	220V	750W	3.5A	2.4N.m	3000rpm	4	
6		80mm	220V	730W	3.0A	3.5N.m	2000rpm	4	
7		80mm	220V	1KW	4.4A	4.0N.m	2500rpm	4	
8		80mm	220V	1KW	4.5A	4.0N.m	3000rpm	4	
3		60mm	220V	400W	4.0A	1.27N.m	3000rpm	4	
9		60mm	220V	100W	0.5A	0.319N.m	3000rpm	4	
10		40mm	220V	100W	0.7A	0.319N.m	3000rpm	4	
11		60mm	220V	200	1.5A	0.637N.m	3000rpm	4	

		m		W		m	m		
12		60m m	220V	400 W	2.8A	1.27N. m	3000rp m	4	
13		60m m	220V	600 W	3.5A	1.91N. m	3000rp m	4	
16		80m m	220V	600 W	3.5A	1.91N. m	3000rp m	4	
21		80m m	220V	400 W	2.0A	1.27N. m	3000rp m	4	
22		80m m	220V	750 W	3.5A	2.4N.m	3000rp m	4	
23		80m m	220V	730 W	3.0A	3.5N.m	2000rp m	4	
24		80m m	220V	1KW	4.4A	4.0N.m	2500rp m	4	

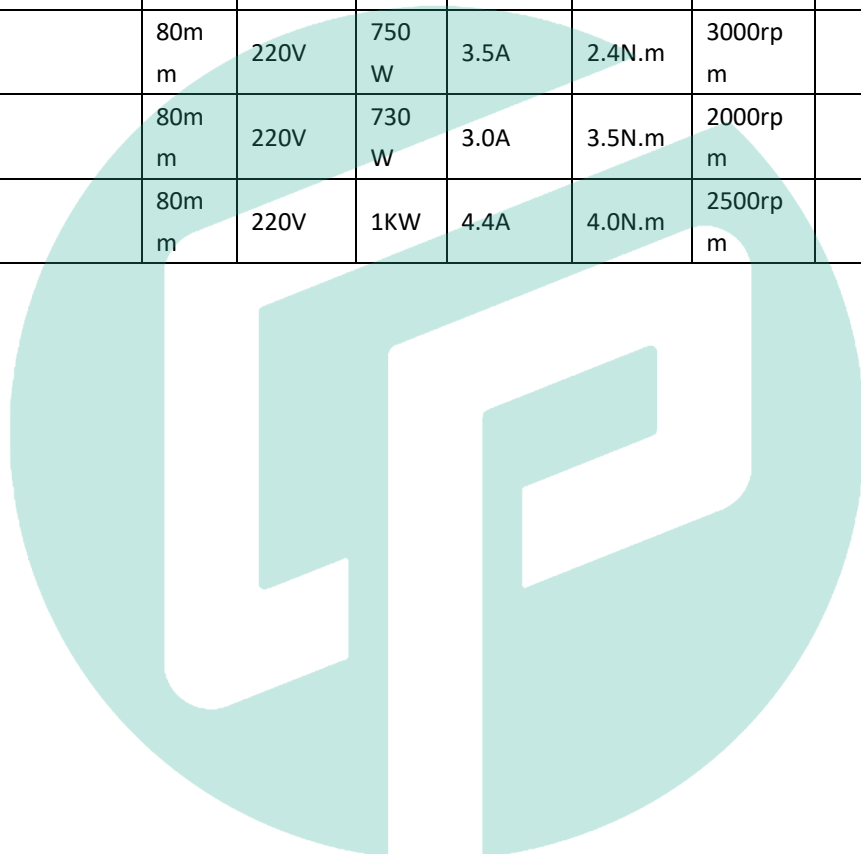

# CNC PARTS