

COLLET ER25
DIN 6499-C32

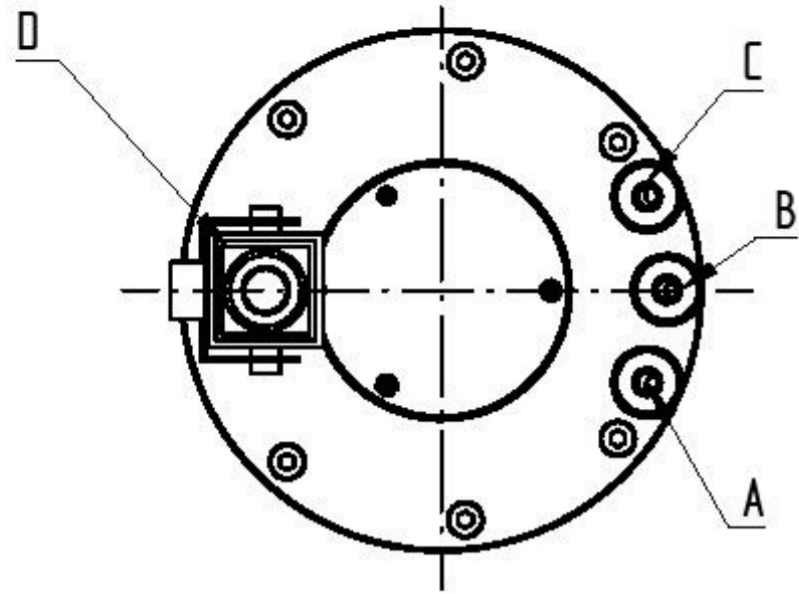

PIN OUT / PIN OUT	
A	Ingresso refrigerante / Coolant IN
B	Pressurizzazione - 0,5bar / Pressurization inlet - 0,5bar
C	Uscita refrigerante / Coolant OUT
D	Potenza / Power

CONNESSIONI ELETTRICHE / ELECTRIC CONNECTIONS	
Nr. Pin	Descrizione / Description
1	U Fase / Motor phase
2	V Fase / Motor phase
3	W Fase / Motor phase
4	** Bimetallo / Bi-metallic
5	** Bimetallo / Bi-metallic
	Terra elettromandrino / Earth connection
Vedi manuale istruzioni ed avvertenze per l'uso per le caratteristiche tecniche	
** See "User's guide" for technical informations	

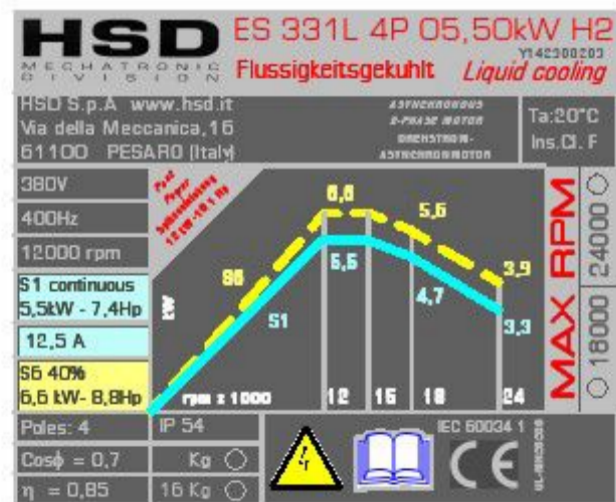

Tensione nominale (*)	Nennspannung (*)	Rated voltage (*)	V	380	380	380
Frequenza nominale	Nennfrequenz	Rated frequency	Hz	400	500	600
Velocità nominale	Nominale Geschwindigkeit	Rated speed	rpm	12000	15000	18000
Tipo di servizio	Betrieb sart	Duty type		S1 cont	S6 40%	S1 cont
Potenza nominale	Nennleistung	Rated power	kW	5,5	6,6	5,5
Coppia nominale	Nennrehm om ent	Rated torque	Nm	4,4	5,3	3,5
Corrente nominale	Nennstrom	Rated current	A	12,5	15	12,5
Rendimento nominale η	Nennwirkungsgrad η	Rated efficiency η			0,85	
Fattore di potenza cos φ	Leistungsfaktor cos φ	Power factor cos φ			0,7	
Momento polare d'inerzia	Polar m om ent of inertia	Trägheitsmoment	kg mm ²			
Numero di poli	Polzahl	Number of poles			4	
Classe di isolamento	Isolierklasse	Insulation class			F	
Classe IP	IP Klasse	IP class			54	
Tipo di raffreddamento	Kühlungstyp	Type of cooling			Raffreddamento a liquido / Flüssigkeit / Liquid cooling	
Consumo aria di pressurizzazione	Verbrauch von Verdichtungsluft	Pressurisation air consumption	l/min	14	14	(0,5 bar, 20°C)
Peso	Gewicht	Weight	kg			~ 15,5

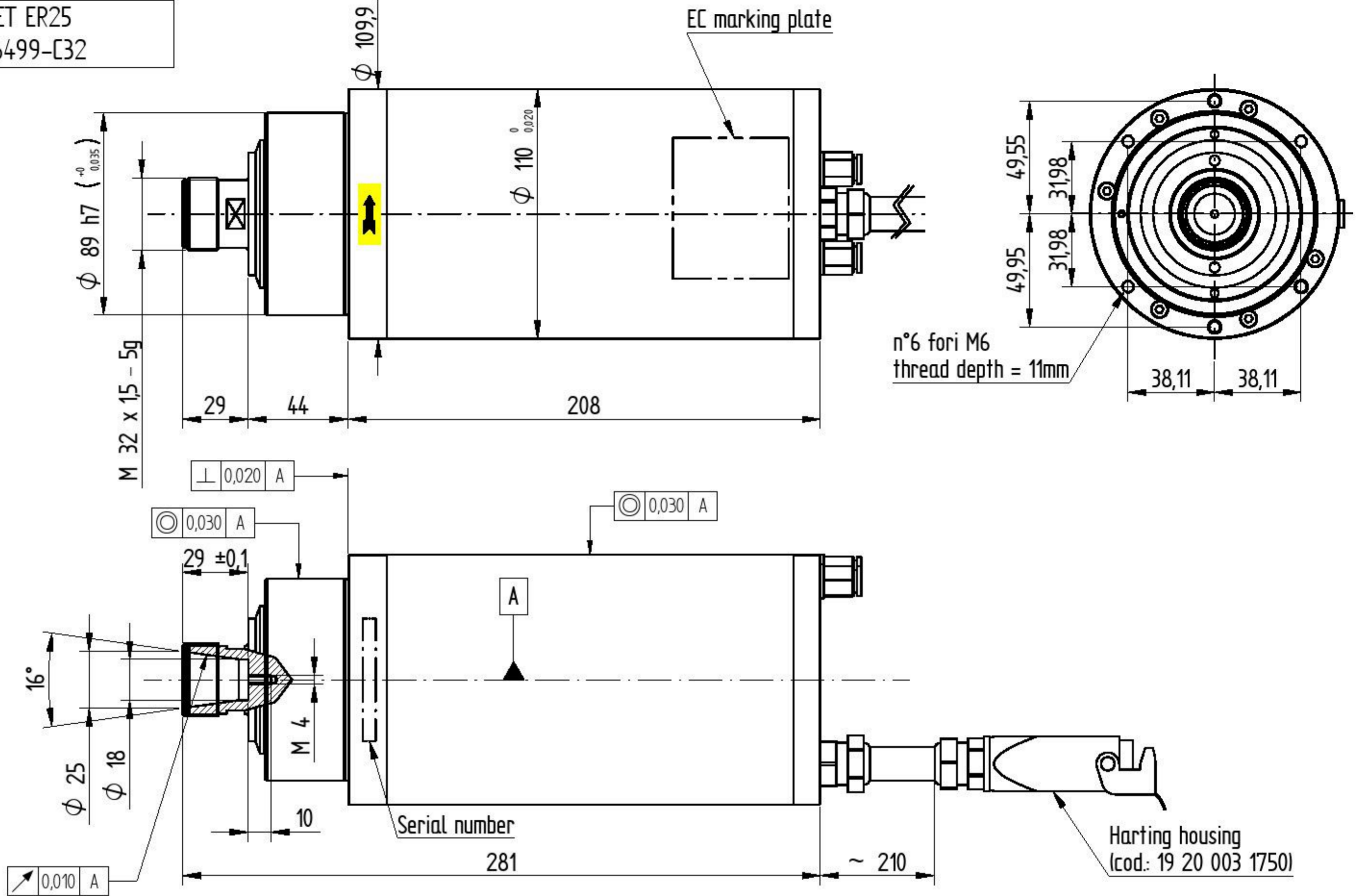

HSD ES 331L 4P 05,50kW H2
MECHATRONIC Flüssigkeitsgekühlt Liquid cooling
HSD s.p.a. www.hsd.it
Via della Meccanica, 16
61100 PESARO (Italy) Ta: 20°C
Ins. Cl. F

CNCPARTS
shop.cncparts.ir
یک خرید مطمئن

RIPRODUZIONE E/O DIFFUSIONE VIETATA / REPRODUCTION AND/OR DISCLOSURE OF THE DRAWING IS FORBIDDEN		DESCRIZIONE REVISIONE / REVISION DESCRIPTION		N°REV	DATA / DATE	FIRMA / SIGN	HSD DIVISION	
REV.							SCALA / SCALE: 1:2	FOGLIO / SHEET: 1/1
DATA DATE	10/11/2015	10/11/2015					A3	
FIRMA SIGN	Bernabucci L.	Bugari M.					QUOTE SENZA INDICAZIONE DI TOLLERANZA / POSITIONS WITHOUT TOLERANCE INFORMATION	
MATERIALE / MATERIAL:							-LAVORAZIONI MECCANICHE / MECHANICAL WORKINGS:	
TRATTAMENTO TERMICO / HEAT TREATMENT:							-SALDOCARPENTERIE / WELDMENT:	
RIVESTIMENTO SUPERFICIALE / SURFACE TREATMENT:							-GETTI / MELT CASTING:	
DENOMINAZIONE / DESCRIPTION:	ES331-ER25-380V-DX-12/18000-5,5KW-S1-INOX+FLASH DI CROMO						CICLO DI VERNICIATURA / PAINTING CYCLE:	
							6162H0120	0