

MODEL : FB

RATIO : 3, 4, 5, 7, 10 (單段 1-Stage)



CNCPARTS



shop.cncparts.ir

یک خرید مطمئن

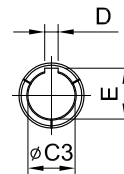
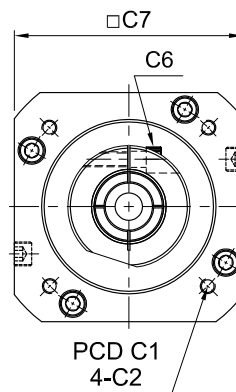
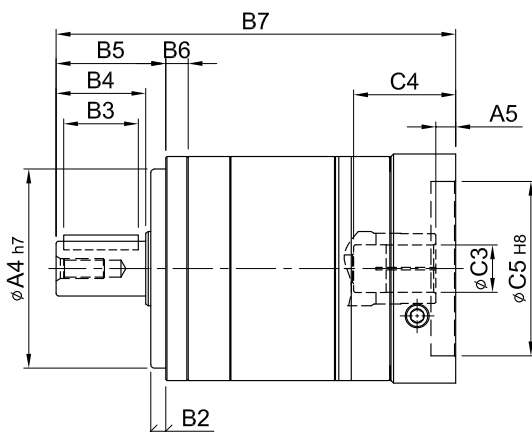
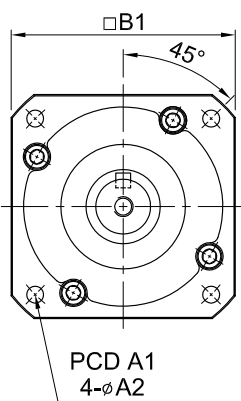
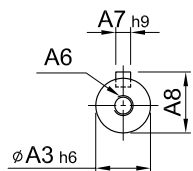

(入力孔φ38(含)以上)

φC3	D	E
φ38	10	41.3
φ42	12	45.3
φ48	14	51.8
φ55	16	59.3

unit: mm

Code	Model	50	70	90	120	145	180	220
A	A1	50	70	100	130	165	215	250
	A2	4.5	6	6.8	9	11	13	17
	A3	13	16	22	32	40	55	75
	A4	35	50	80	110	130	160	180
	A5	5	6	9·23.5	10·20	10	13·15	13.5·15.5
	A6	M4 x P0.7	M5 x P0.8	M8 x P1.25	M10 x P1.5	M12 x P1.75	M14 x P2.0	M16 x P2.0
	A7	5	5	6	10	12	16	20
	A8	15	18	24.5	35	43	59	81
B	B1	50	70	90	120	145	180	220
	B2	4	5	8	8	10	20	20
	B3	15	20	30	40	65	70	90
	B4	20	28	36	50	74	82	104
	B5	25	34	44	60	87	106	129
	B6	6	8	9	12	15	16	24
	B7	100.5	132.5·140.5	170.5·185	227.5	284	325·327	377·379
C	C1	46·60·63	70·75·90	90·100·115·145	115·145·165	145·165·215	200·215·265	200·265·300
	C2	M3 M4 M5	M4 M5 M6	M5 M6 M8	M6 M8 M10	M8 M10 M12	M10 M12	M12 M16
	C3	8·9·11	11·14	16·19·22·24	24·28·32	28·32·35·38	35·38·42·48	42·48·55
	C4	26	33.5·41.5	51·65.5	63·73	81.5	115·117	118·120
	C5	30·40·50	40·50·60	70·80·95·110	95·110·130	110·130·180	114.3·180·230	114.3·230·250
	C6	M4 x P0.7	M5 x P0.8	M6 x P1.0	M8 x P1.25	M10 x P1.5	M10 x P1.5	M10 x P1.5
	C7	46·55	64·70·80	92·110·130	122·130·150	146·150·190	182·200·250	222·250·265

تهران، خیابان سعدی جنوبی، چهارراه اکباتان کوچه ناظم الاطبا شمالی، ابتدای کوچه، پلاک ۱۶۷
 ۳۶۶۱۹۳۹۰ - ۳۶۶۱۹۵۱۰ - ۳۳۵۳۲۱۹۴ - ۳۳۹۵۹۰۳۴ - ۳۳۹۵۹۷۵۶ - ۳۳۹۵۹۳۲۶

Characteristic of FB 1-Stage

FB 單段特性

CNCPARTS



shop.cncparts.ir

یک خرید مطمئن

規格 Model No.	代號	單位 Unit	速比 Ratio	50	70	90	120	145	180	220
額定輸出扭矩 / Rated Output Torque (Nominal output torque)	T_{2N}	Nm	3	17	50	125	268	482	940	1,420
			4	15	45	111	238	426	860	1,300
			5	14	42	104	223	401	835	1,270
			7	13	39	98	208	373	790	1,180
			10	12	37	92	198	356	760	1,140
最大加速扭矩 / Max. Acceleration Torque	T_{2B}	Nm	3~10	1.8 倍額定輸出扭矩 1.8 Times of Rated Output Torque						
最大輸出扭矩 / Max. Output Torque 急停扭矩 / Emergency Stop Torque	T_{2NOT}	Nm	3~10	3 倍額定輸出扭矩 3 Times of Rated Output Torque						
額定輸入轉速 / Rated Input Speed	n_{1N}	rpm	3~10	3,000	3,000	3,000	3,000	3,000	2,000	2,000
最大輸入轉速 / Max. Input Speed	n_{1B}	rpm	3~10	5,000	5,000	5,000	5,000	5,000	3,000	3,000
背隙 / Backlash		arcmin	3~10	≤ 8	≤ 8	≤ 8	≤ 8	≤ 8	≤ 8	≤ 8
扭轉剛性 / Torsional Rigidity		Nm/arcmin	3~10	2.3	5	15	45	69	140	220
容許徑向力 / Max. Radial Force	F_{2rB}	N	3~10	750	1,180	3,000	6,500	9,100	11,150	35,000
容許軸向力 / Max. Axial Force	F_{2aB}	N	3~10	325	590	1,500	3,250	4,550	5,575	17,500
使用壽命 / Service Life	L_{H1}	hr	3~10	S5 周期運轉: >30,000 (S1 連續運轉: >15,000 hrs) S5 Cycle Operation: >30,000 (S1 Continuous Operation: >15,000 hrs)						
效率 / Efficiency	η	%	3~10	≥ 97%						
使用溫度 / Operating Temperature		°C	3~10	-25° C ~ +90° C						
潤滑 / Lubrication			3~10	全合成潤滑油脂 Synthetic Grease						
防護等級 / Protection Class			3~10	IP65						
安裝方向 / Mounting Position			3~10	任意方向 Any						
噪音值 / Noise Level		dB	3~10	≤ 62	≤ 62	≤ 65	≤ 68	≤ 70	≤ 70	≤ 70
重量 / Weight ±3%		Kg	3~10	0.63	1.57	3.22	8	16	33	54

تهران، خیابان سعدی جنوبی، چهارراه اکباتان کوچه ناظم الاطبا شمالی، ابتدای کوچه، پلاک ۱۶۷
۳۶۶۱۹۳۹۰ - ۳۶۶۱۹۵۱۰ - ۳۳۵۳۲۱۹۴ - ۳۳۹۵۹۰۳۴ - ۳۳۹۵۹۷۵۶ - ۳۳۹۵۹۳۲۶

CNCPARTS



Mass Moments of Inertia (kg.cm²)

速比 Ratio	50	70	90	120	145	180	220
3	0.04	0.14	0.61	3.25	8.75	24.63	50.67
4	0.04	0.13	0.48	2.74	7.16	20.12	46.21
5	0.04	0.11	0.47	2.74	6.84	19.80	45.28
7	0.04	0.11	0.44	2.58	6.78	19.21	43.32
10	0.04	0.11	0.44	2.57	6.68	19.13	42.98