



راهنمای کاربر

DM542

Fully Digital Stepping Drive

Attention: Please read this manual carefully before using the Drive!

<https://shop.cncparts.ir>

SHENZHEN ECON TECHNOLOGY CO.,LTD

CNC PARTS

Contents

1 Introduction, Features and Applications.....	3	12. Frequently Asked Questions	9
1.1 Introduction.....	3	Problem Symptoms and Possible Causes.....	10
1.2 Features.....	3	13 Warranty	10
1.3 Applications.....	3	Exclusions	10
2. Specifications	3	Obtaining Warranty Service	11
2.1 Electrical Specifications ($T_j = 25\text{ }^\circ\text{C}/77\text{ }^\circ\text{F}$).....	3	Warranty Limitations	11
2.2 Mechanical Specifications (unit: mm [inch]).....	3	Contact us	11
2.3 Elimination of Heat	4		
2.4 Operating Environment and other Specifications	4		
3. Pin Assignment and Description	4		
3.1 Connector P1 Configurations	4		
3.2 Connector P2 Configurations	4		
4. Control Signal Connector (P1) Interface	5		
5. Connecting the Motor	5		
5.1 Connections to 4-lead Motors	5		
5.2 Connections to 6-lead Motors	5		
5.3 Half Coil Configurations.....	5		
5.4 Full Coil Configurations	6		
5.5 Connections to 8-lead Motors	6		
6. Power Supply Selection.....	6		
6.1 Regulated or Unregulated Power Supply.....	6		
6.2 Multiple Drives	7		
6.3 Selecting Supply Voltage	7		
7. Selecting Microstep Resolution and Drive Output Current	7		
7.1 Microstep Resolution Selection	7		
7.2 Current Settings.....	7		
8. Wiring Notes.....	8		
9. Typical Connection.....	8		
10. Protection Functions	9		

CNC PARTS

applications that require both low-speed smoothness and high speed performances.

۲- Specifications

معرفی، ویژگی‌ها و کاربردها ۱

معرفی ۱.۱

DM542 یک درایو پله‌ای (stepper drive) کاملاً دیجیتال همه‌کاره مبتنی بر DSP با الگوریتم کنترل پیشرفته است. DM542 جدیدترین نسل کنترل‌های موتور پله‌ای دیجیتال است. این موتور سطح منحصر به فردی از نرمی سیستم را به ارمغان می‌آورد و گشتاور بهینه را فراهم می‌کند و بی‌ثباتی در محدوده میانی را حذف می‌کند. فناوری خودآزمایی موتور و تنظیم خودکار پارامترها، پاسخ‌های بهینه را با موتورهای مختلف ارائه می‌دهد و استفاده از آن آسان است. موتورها می‌توانند با نویز بسیار کم، گرمای کم و حرکت روان کار کنند. ویژگی‌های منحصر به فرد آن، DM542 را به یک راه حل ایده‌آل برای کاربردهایی تبدیل می‌کند که نیاز به حرکت روان در سرعت پایین دارند.

ویژگی‌ها ۱.۲

- Anti-Resonance, provides optimum torque and nulls mid-range instability
- Motor parameter auto-tuning technology, offers optimum responses with different motors for smooth system performance
- Microstep resolutions programmable, from full-step to 102,400 steps/rev
- Output current programmable, from 0.5A to 4.2A(peak)
- Pulse input frequency up to 200 KHz
- TTL compatible and optically isolated input
- Automatic idle-current reduction
- Suitable for 2-phase and 4-phase motors
- Support PUL/DIR and CW/CCW modes
- Over-voltage, over-current, phase-error protections

1.3 Applications

It can be used in various kinds of machines, such as laser cutters, laser markers, high precision X-Y tables, labeling machines, and so on. Its unique features make the DM542 an ideal solution for

2.1 Electrical Specifications ($T_j = 25\text{ }^\circ\text{C}/77\text{ }^\circ\text{F}$)

Parameters	DM542			Unit
	Min	Typical	Max	
Output current[PK]	0.5	-	4.20(3.0 RMS)	A
Supply voltage	24	36	50	Vdc
Pulse Voltage	4.5	5	28	Vdc
Logic signal current	7	10	16	mA
Pulse input frequency	0	-	200	KHz
Isolation resistance	100	-	-	MΩ

2.2 Mechanical Specifications (unit: mm [inch])

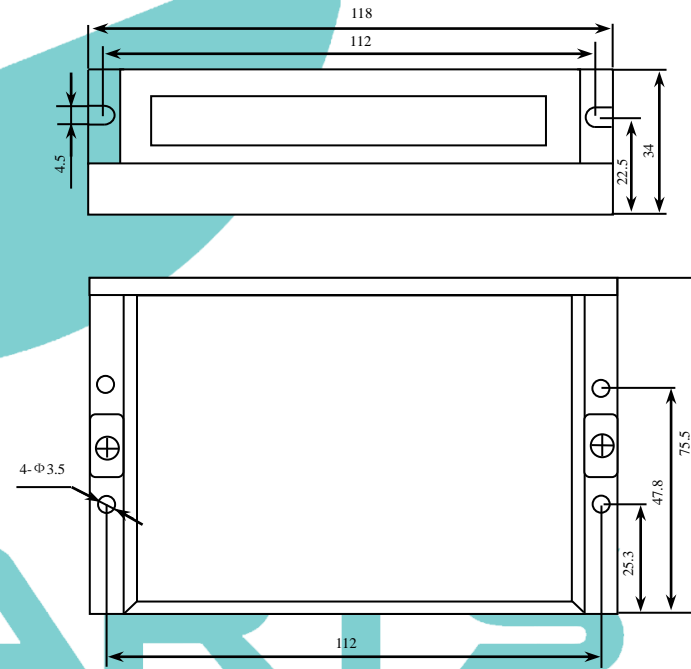

Figure 1: Mechanical specifications

نشانی: تهران - خیابان سعدی جنوبی - چهارراه اکباتان ناظم الاطبا شمالی - پلاک ۱۶۷

تلفن: ۰۲۱-۳۳۵۳۲۶۰۲ - ۳۳۹۵۹۳۲۶ - ۳۳۵۳۲۱۹۴ - ۳۳۹۵۹۷۵۶ - ۳۳۹۵۹۷۵۶ - ۳۶۶۱۹۵۱۰ - ۳۶۶۱۹۳۹۰

2.3 Elimination of Heat

- Drive's reliable working temperature should be <70°C (158°F), and motor working temperature should be <80°C (176°F);
- It is recommended to use automatic idle-current mode, namely current automatically reduce to 60% when motor stops, so as to reduce Drive heating and motor heating;
- The Drive must be mounted vertically to maximize heat sink area as shown in the following picture. Use forced cooling method to cool the system if necessary.

2.4 Operating Environment and other Specifications

Cooling	Natural Cooling or Forced cooling	
Operating Environment	Environment	Avoid dust, oil fog and corrosive gases
	Ambient Temperature	0°C — 50°C (32°F — 122°F)
	Humidity	40%RH — 90%RH
	Operating Temperature	70°C (158°F) Max
Storage Temperature	-20 °C — 65°C (-4°F — 149°F)	
Weight	Approx. 280g (10 oz)	

۴. Pin Assignment and Description

The DM542 has two connectors, connector P1 for control signals connections, and connector P2 for power and motor connections. The following tables are brief descriptions of the two connectors. More detailed descriptions of the pins and related issues are presented in section 4, 5, 9.

3.1 Connector P1 Configurations

Pin	Details
-----	---------

Function	
PUL+	Pulse signal: In Pulse+direction mode, this input represents pulse signal, active at each rising or falling edge 4-28V for PUL-HIGH, 0-0.5V for PUL-LOW. For reliable response, pulse width should be longer than 2.5μs for 200K MAX input frequency or 1μs for 500K MAX input frequency.
PUL-	
DIR+	Dir signal: In Pulse+direction mode, this signal has low/high voltage levels representing two directions of motor rotation; For reliable motion response, DIR signal should be ahead of PUL signal by 2.5μs at least. 4-28V when DIR-HIGH, 0-0.5V when DIR-LOW. Please note that rotation direction is also related to motor-Drive wiring match. Exchanging the connection of two wires for a coil to the Drive will reverse motion direction.
DIR-	
ENA+	Enable signal: This signal is used for enabling/disabling the Drive. High level (NPN control signal, PNP and Differential control signals are on the contrary, namely Low level for enabling.) for enabling the Drive and low level for disabling the Drive. Usually left UNCONNECTED (ENABLED).
ENA-	

Note! DM542 don't support CW/CCW pulse mode

3.2 Connector P2 Configurations

Pin Function	Details
GND	Power Ground.
+Vdc	Power supply, 24-50 Vdc, Including voltage fluctuation and EMF voltage.
A+, A-	Motor Phase A
B+, B-	Motor Phase B

۴. Control Signal Connector (P1) Interface

The DM542 can accept differential and single-ended inputs (including open-collector and PNP output). The DM542 has 3 optically isolated logic inputs which are located on connector P1 to accept line Drive control signals. These inputs are isolated to minimize or eliminate electrical noises coupled onto the Drive control signals. Recommend use line Drive control signals to increase noise immunity of the Drive in interference environments. In the following figures, connections to open-collector and PNP signals are illustrated.

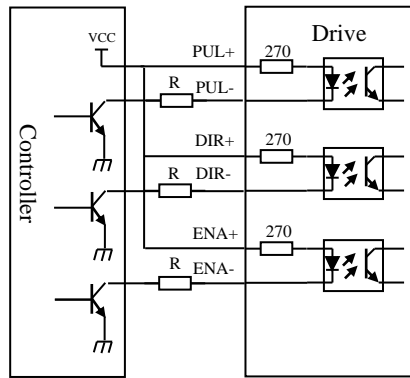

Figure 2 Connections to open-collector signal

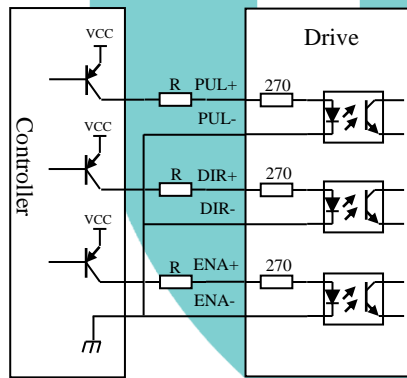

Figure 3 Connections to PNP

Note! If $VCC=4 \sim 28Vdc$, R should be connected base on input voltage;

۵. Connecting the Motor

The DM542 can Drive any 2-pahse and 4-pahse hybrid stepping motors.

5.1 Connections to 4-lead Motors

4 lead motors are the least flexible but easiest to wire. Speed and torque will depend on

winding inductance. In setting the Drive output current, multiply the specified phase current by 1.4 to determine the peak output current.

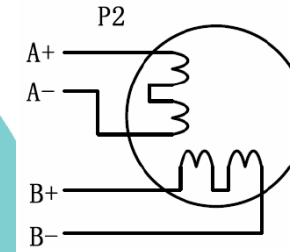

Figure 4: 4-lead Motor Connections

5.2 Connections to 6-lead Motors

Like 8 lead stepping motors, 6 lead motors have two configurations available for high speed or high torque operation. The higher speed configuration, or half coil, is so described because it uses one half of the motor's inductor windings. The higher torque configuration, or full coil, uses the full windings of the phases.

5.3 Half Coil Configurations

As previously stated, the half coil configuration uses 50% of the motor phase windings. This gives lower inductance, hence, lower torque output. Like the parallel connection of 8 lead motor, the torque output will be more stable at higher speeds. This configuration is also referred to as half chopper. In setting the Drive output current multiply the specified per phase (or unipolar) current rating by 1.4 to determine the peak output current.

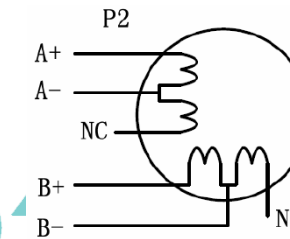

Figure 5: 6-lead motor half coil (higher speed) connections

5.4 Full Coil Configurations

The full coil configuration on a six lead motor should be used in applications where higher torque at lower speeds is desired. This configuration is also referred to as full copper. In full coil mode, the motors should be run at only 70% of their rated current to prevent over heating.

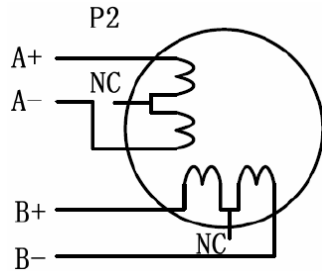

Figure 6: 6-lead motor full coil (higher torque) connections

5.5 Connections to 8-lead Motors

8 lead motors offer a high degree of flexibility to the system designer in that they may be connected in series or parallel, thus satisfying a wide range of applications.

Series Connections

A series motor configuration would typically be used in applications where a higher torque at lower speeds is required. Because this configuration has the most inductance, the performance will start to degrade at higher speeds. In series mode, the motors should also be run at only 70% of their rated current to prevent over heating.

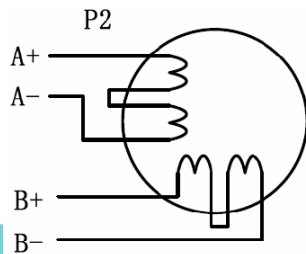

Figure 7: 8-lead motor series connections

Parallel Connections

An 8 lead motor in a parallel configuration offers a more stable, but lower torque at lower speeds. But because of the lower inductance, there will be higher torque at higher speeds. Multiply the per phase (or unipolar) current rating by 1.96, or the bipolar current rating by 1.4, to determine the peak output current.

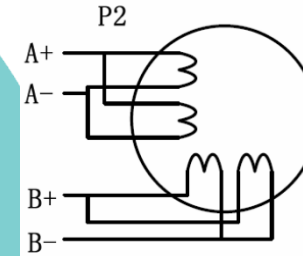

Figure 8: 8-lead motor parallel connections

NEVER disconnect or connect the motor while the power source is energized.

۶. Power Supply Selection

The DM542 can match motors from NEMA frame size 14 to nema23 .To achieve good driving performances, it is important to select supply voltage and output current properly. Generally speaking, supply voltage determines the high speed performance of the motor, while output current determines the output torque of the Drive motor (particularly at lower speed). Higher supply voltage will allow higher motor speed to be achieved, at the price of more noise and heating. If the motion speed requirement is low, it's better to use lower supply voltage to decrease noise, heating and improve reliability.

6.1 Regulated or Unregulated Power Supply

Both regulated and unregulated power supplies can be used to supply the Drive. However, unregulated power supplies are preferred due to their ability to withstand current surge. If regulated power supplies (such as most switching supplies.) are indeed used, it is important to have large current output rating to avoid problems like current clamp, for example using 4A supply for 3A motor-Drive operation. On the other hand, if unregulated supply is used, one may use a power supply of lower current rating than that of motor (typically 50% ~70% of motor current). The reason is that the Drive draws current from the power supply capacitor of the unregulated supply



only during the ON duration of the PWM cycle, but not during the OFF duration. Therefore, the average current withdrawn from power supply is considerably less than motor current. For example, two 3A motors can be well supplied by one power supply of 4A rating.

6.2 Multiple Drives

It is recommended to have multiple Drives to share one power supply to reduce cost, if the supply has enough capacity. To avoid cross interference, **DO NOT** daisy-chain the power supply input pins of the Drives. Instead, please connect them to power supply separately.

6.3 Selecting Supply Voltage

The power MOSFETS inside the DM542 can actually operate within +24 ~ +50Vdc, including power input fluctuation and back EMF voltage generated by motor coils during motor shaft deceleration. Higher supply voltage can increase motor torque at higher speeds, thus helpful for avoiding losing steps. However, higher voltage may cause bigger motor vibration at lower speed, and it may also cause over-voltage protection or even Drive damage. Therefore, it is suggested to choose only sufficiently high supply voltage for intended applications, and it is suggested to use power supplies with theoretical output voltage of +24 ~ +50Vdc, leaving room for power fluctuation and back-EMF.

γ. Selecting Microstep Resolution and Drive Output

Current

Microstep resolutions and output current are programmable, the former can be set from full-step to 102,400 steps/rev and the latter can be set from 0.5A to 5.0A. See more information about **Microstep and Output Current Setting** in Section 13. However, when it's not in software configured mode, this Drive uses an 8-bit DIP switch to set microstep resolution, and motor operating current, as shown below:



Standstill Current(ON haft/OFF full)

7.1 Microstep Resolution Selection

When it's not in software configured mode, microstep resolution is set by SW5, 6, 7, 8 of the DIP switch as shown in the following table:

Microstep	Steps/rev.(for 1.8°motor)	SW5	SW6	SW7	SW8
1 to 512	Default/Software configured	ON	ON	ON	ON
2	400	OFF	ON	ON	ON
4	800	ON	OFF	ON	ON
8	1600	OFF	OFF	ON	ON
16	3200	ON	ON	OFF	ON
32	6400	OFF	ON	OFF	ON
64	12800	ON	OFF	OFF	ON
128	25600	OFF	OFF	OFF	ON
5	1000	ON	ON	ON	OFF
10	2000	OFF	ON	ON	OFF
20	4000	ON	OFF	ON	OFF
25	5000	OFF	OFF	ON	OFF
40	8000	ON	ON	OFF	OFF
50	10000	OFF	ON	OFF	OFF
100	20000	ON	OFF	OFF	OFF
125	25000	OFF	OFF	OFF	OFF

7.2 Current Settings

For a given motor, higher Drive current will make the motor to output more torque, but at the same time causes more heating in the motor and Drive. Therefore, output current is generally set to be such that the motor will not overheat for long time operation. Since parallel and serial connections of motor coils will significantly change resulting inductance and resistance, it is therefore important to set Drive output current depending on motor phase current, motor leads and connection methods. Phase current rating supplied by motor manufacturer is important in selecting

Drive current, however the selection also depends on leads and connections.

When it's not in software configured mode, the first three bits (SW1, 2, 3) of the DIP switch are used to set the dynamic current. Select a setting closest to your motor's required current.

Dynamic current setting

Peak Current	RMS Current	SW1	SW2	SW3
Default/Software configured		ON	ON	ON
1.46A	1.04A	OFF	ON	ON
1.91A	1.36A	ON	OFF	ON
2.37A	1.69A	OFF	OFF	ON
2.84A	2.03A	ON	ON	OFF
3.31A	2.36A	OFF	ON	OFF
3.76A	2.69A	ON	OFF	OFF
5.00A	3.57A	OFF	OFF	OFF

Notes: Due to motor inductance, the actual current in the coil may be smaller than the dynamic current setting, particularly under high speed condition.

Standstill current setting

SW4 is used for this purpose. OFF meaning that the standstill current is set to be half of the selected dynamic current, and ON meaning that standstill current is set to be the same as the selected dynamic current.

The current automatically reduced to 60% of the selected dynamic current one second after the last pulse. Theoretically, this will reduce motor heating to 36% (due to $P=I^2 \cdot R$) of the original value. If the application needs a different standstill current, please contact ECON technology

1. Wiring Notes

In order to improve anti-interference performance of the Drive, it is recommended to use twisted pair shield cable.

To prevent noise incurred in PUL/DIR signal, pulse/direction signal wires and motor wires should not be tied up together. It is better to separate them by at least 10 cm, otherwise the disturbing signals generated by motor will easily disturb pulse direction signals, causing motor

position error, system instability and other failures .If a power supply serves several Drives, separately connecting the Drives is recommended instead of daisy-chaining.

It is prohibited to pull and plug connector P2 while the Drive is powered ON, because there is high current flowing through motor coils (even when motor is at standstill). Pulling or plugging connector P2 with power on will cause extremely high back-EMF voltage surge, which may damage the Drive.

9. Typical Connection

A complete stepping system should include stepping motor, stepping Drive, power supply and controller (pulse generator). A typical connection is shown as figure 9.

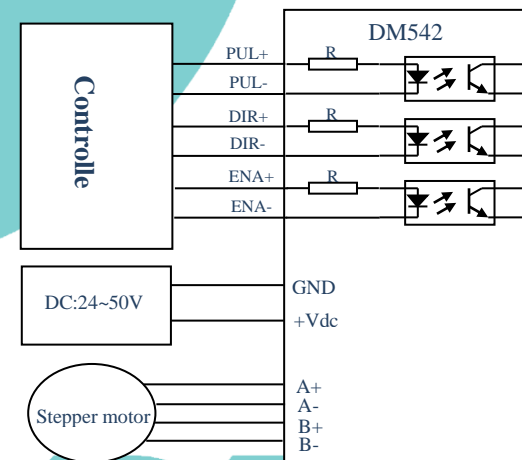

Figure 9 DM542 Typical connection

10. Sequence Chart of Control Signals

In order to avoid some fault operations and deviations, PUL, DIR and ENA should abide by some rules, shown as following diagram:

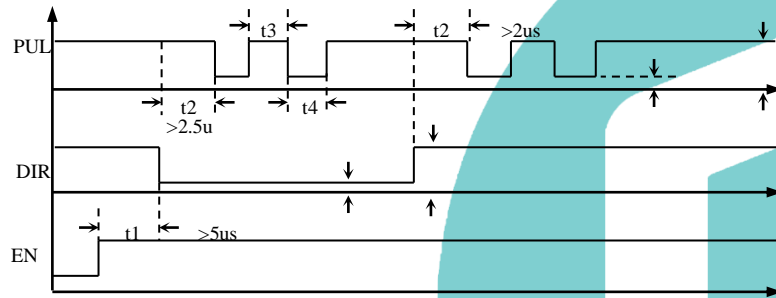

Figure 10: Sequence chart of control signals

Remark:

- t1: ENA must be ahead of DIR by at least 5s. Usually, ENA+ and ENA- are NC (not connected). See “Connector P1 Configurations” for more information.
- t2: DIR must be ahead of PUL active edge by 2.5s to ensure correct direction;
- t3: Pulse width not less than 2s;
- t4: Low level width not less than 2s.

11. Protection Functions

To improve reliability, the Drive incorporates some built-in protection functions. The DM542 uses one RED LED to indicate what protection has been activated. The periodic time of RED is 3 s (seconds), and how many times the RED turns on indicates what protection has been activated. Because only one protection can be displayed by RED LED, so the Drive will decide what error to display according to their priorities. See the following Protection Indications table for displaying priorities.

Over-current Protection

Over-current protection will be activated when continuous current exceeds 22A or in case of short circuit between motor coils or between motor coil and ground, and RED LED will turn on once

within each periodic time (3 s).

Over-voltage Protection

When power supply voltage exceeds 92 ± 1 VDC, protection will be activated and RED LED will turn on twice within each periodic time (3 s).

Phase Error Protection

Motor power lines wrong & not connected will activate this protection. RED LED will turn on four times within each periodic time (3 s).

Attention: When above protections are active, the motor shaft will be free or the LED will turn red.

Reset the Drive by repowering it to make it function properly after removing above problems.

Since there is no protection against power leads (+, -) reversal, it is critical to make sure that power supply leads correctly connected to Drive. Otherwise, the Drive will be damaged instantly.

Protection Indications

Priority	Time(s) of ON	Sequence wave of RED LED	Description
1st	1	□	Over-current protection
2nd	2	□□	Over-voltage protection
3rd	4	□□□□	NC

12. Frequently Asked Questions

In the event that your Drive doesn't operate properly, the first step is to identify whether the problem is electrical or mechanical in nature. The next step is to isolate the system component that is causing the problem. As part of this process you may have to disconnect the individual components that make up your system and verify that they operate independently. It is important to document each step in the troubleshooting process. You may need this documentation to refer back to at a later date, and these details will greatly assist our Technical Support staff in determining the



problem should you need assistance.

Many of the problems that affect motion control systems can be traced to electrical noise, controller software errors, or mistake in wiring.

Problem Symptoms and Possible Causes

Symptoms	Possible Problems
Motor is not rotating	No power
	Microstep resolution setting is wrong
	DIP switch current setting is wrong
	Fault condition exists
Motor rotates in the wrong direction	The Drive is disabled
	Motor phases may be connected in reverse
The Drive in fault	DIP switch current setting is wrong
	Something wrong with motor coil
Erratic motor motion	Control signal is too weak
	Control signal is interfered
	Wrong motor connection
	Something wrong with motor coil
Motor stalls during acceleration	Current setting is too small, losing steps
	Current setting is too small
	Motor is undersized for the application
	Power supply voltage too low
Excessive motor and Drive heating	Acceleration is set too high
	Inadequate heat sinking / cooling
	Automatic current reduction function not being utilized
	Current is set too high

۱۳ Warranty

Shenzhen ECON Technology Co., Ltd. warrants its products against defects in materials and workmanship for a period of 12 months from shipment out of factory. During the warranty period, ECON technology will either, at its option, repair or replace products which proved to be defective.

Exclusions

The above warranty does not extend to any product damaged by reasons of improper or inadequate handlings by customer, improper or inadequate customer wirings, unauthorized modification or misuse, or operation beyond the electrical specifications of the product and/or operation beyond environmental specifications for the product.

Obtaining Warranty Service

Technical support: technical01@hybridservo.com

To obtain warranty service, a returned material authorization number (RMA) must be obtained from customer service at e-mail: technical01@hybridservo.com before returning product for service. Customer shall prepay shipping charges for products returned to ECON technology for warranty service, and ECON technology shall pay for return of products to customer.

Warranty Limitations

ECON technology makes no other warranty, either expressed or implied, with respect to the product. ECON technology specifically disclaims the implied warranties of merchantability and fitness for a particular purpose. Some jurisdictions do not allow limitations on how long and implied warranty lasts, so the above limitation or exclusion may not apply to you. However, any implied warranty of merchantability or fitness is limited to the 12-month duration of this written warranty.

Contact us

Shenzhen ECON Technology Co.,Ltd

**Add:ROOM 1405,14TH FLOOR,5TH PHASE NO.2 BUILDING,1980
FUCHENG DIGITAL INNOVATION PARK,FUCHENG
STREET, LONGHUA DISTRICT, SHENZHEN, CHINA**

Tel: +86 136 2096 1024

Sales: enquiry@hybridservo.com

CNC PARTS

نشانی: تهران - خیابان سعدی جنوبی - چهارراه اکباتان ناظم الاطبای شمالی - پلاک ۱۶۷

تلفن: ۰۳۶۶۱۹۳۹۰ - ۳۶۶۱۹۵۱۰ - ۳۳۹۵۹۷۵۶ - ۳۳۹۵۹۷۵۶ - ۳۳۵۳۲۱۹۴ - ۳۳۹۵۹۳۲۶ - ۰۲ - ۳۳۵۳۲۶۰