

User Manual
For TS808C
Vector Hybrid Servo Drive

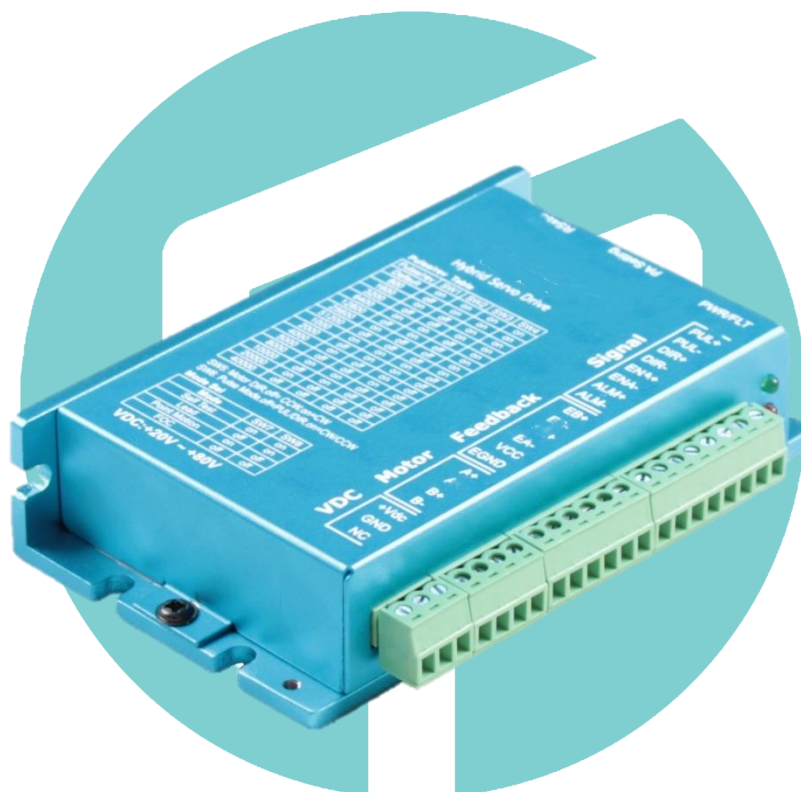

CNC PARTS



Notice!

Read this manual carefully before any assembling and using. Incorrect handling of products in this manual can result in injury and damage to persons and machinery. Strictly adhere to the technical information regarding installation requirements.

This manual is not for use or disclosure outside of JKON-TEK technology except under permission. All rights are reserved. No part of this manual shall be reproduced, stored in retrieval form, or transmitted by any means, electronic, mechanical, photocopying, recording, or otherwise without approval from JKON-TEK technology. While every precaution has been taken in the preparation of the book, JKON-TEK technology assumes no responsibility for errors or omissions. Neither is any liability assumed for damages resulting from the use of the information contained herein.

This document is proprietary information of JKON-TEK technology that is furnished for customer use ONLY. Information in this document is subject to change without notice and does not represent a commitment on the part of JKON-TEK technology. Therefore, information contained in this manual may be updated from time-to-time due to product improvements, etc., and may not conform in every respect to former issues.

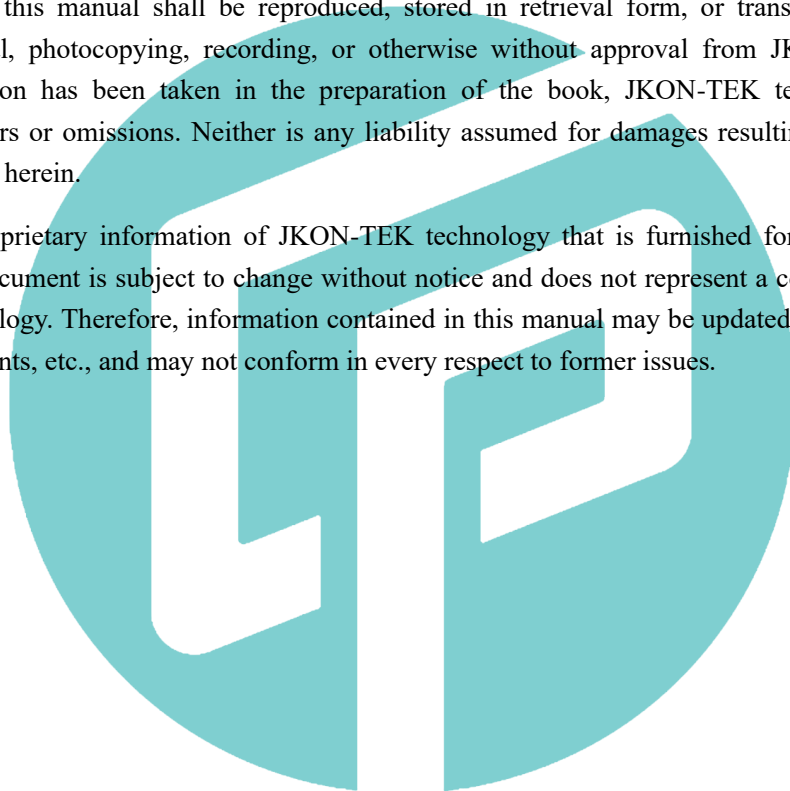

CNC PARTS

نشانی: تهران - خیابان سعدی جنوبی - چهارراه اکباتان ناظم الاطبا شمالی - پلاک ۱۶۷

تلفن: ۳۶۶۱۹۳۹۰ - ۳۶۶۱۹۵۱۰ - ۳۳۹۵۹۷۵۶ - ۳۳۹۵۹۷۵۶ - ۳۳۵۳۲۱۹۴ - ۳۳۹۵۹۳۲۶ - ۳۳۵۳۲۶۰۲

<https://shop.cncparts.ir>

contents

1 Introduction	4
2 Features	4
3 Applications	4
4 Specifications	5
4.1 Electrical Specifications	5
4.2 Operating Environment	5
5 Mechanical Specifications	5
6 Connectors and Pin Assignment	6
6.1 Control signals connector	6
6.2 Encoder Feedback Connector	7
6.3 Power and Motor	7
6.4 RS232/RS485 Communication Port	7
7 DIP Switch Settings	8
7.1 Microstep Revolution (SW1-SW4)	8
7.2 Motor Direction (SW5) and Mode sel (SW6)	8
7.3 Motor Sel (SW7-SW8)	8
7.4 Current Control	9
8 Hybrid servo Motors	9
8.1 Nema17 hybrid servo motors	9
8.2 Nema23 hybrid servo motors	9
8.3 Nema24 hybrid servo motors	10
8.4 Nema34 hybrid servo motors	10
8.5 Motor Encoder Cable Connector	10
8.6 Motor Encoder Extension Cable	11
9 Wiring Diagrams	11
9.1 Interface	11
9.2 Diagram	11
9.3 Control Signal Wiring	12
Wiring Notes	12
10 Protection Indications	12
11 Frequently Asked Questions	12
Problem Symptoms and Possible Causes	13
12 Warranty	13
Exclusions	13
Obtaining Warranty Service	13

نشانی: تهران - خیابان سعدی جنوبی - چهارراه اکباتان ناظم الاطبا شمالی - پلاک ۱۶۷

تلفن : ۳۳۵۳۲۶۰۲ - ۳۳۹۵۹۳۲۶ - ۳۳۵۳۲۱۹۴ - ۳۳۹۵۹۷۵۶ - ۳۳۹۵۹۷۵۶ - ۳۶۶۱۹۵۱۰ - ۳۶۶۱۹۳۹۰

1 Introduction

TS808C is one of JKON-TEK technology's TS series hybrid servo drives, its power input is 24-80 VDC, and the output current is 0.5 -8A(peak). It can match Nema17,23,24 and 34 hybrid servo motors (stepper motor with encoder) with the position loop closed in real time.

Based on latest DSP technology and JKON-TEK technology's advanced control algorithm, TS808C hybrid servo drive applies servo vector control for hybrid servo motor. It combines features of both open loop steppers and brushless servo systems, and offers many unique advanced features for excellent motion control system performance.

When an TS808C hybrid servo drive is implemented with a JKON-TEK technology's TC series hybrid servo motor, there is No Configuration Needed for almost all applications. The default resolution is 2,000 pulses, and the user can also easily change the output resolution to resolutions 400 to 51,200 via DIP switches. With JKON-TEK technology's ProTuner, user can also set custom settings of resolution, current & position loop parameters, idle current percentage, etc.

2 Features

- ✧ Step and direction control
- ✧ Closed position loop for no loss of movement synchronization
- ✧ Input power range: 24-80 VDC
- ✧ Output current of 0.5 - 8 A(PEAK)
- ✧ High torque at starting and low speed
- ✧ No torque reservation
- ✧ High stiffness at standstill
- ✧ Significantly reduced motor heating
- ✧ Smooth movement and extra low noise
- ✧ Quick response, no delay and zero settling time
- ✧ No loss of steps; no hunting; no overshooting

3 Applications

With many unique advanced features, JKON-TEK technology's TS808C hybrid servo systems are ideal for many industries to upgrade stepper performance or replace AC/DC brushless servo systems in many applications

JKON-TEK technology's clients have successfully implemented TS808C hybrid servo systems in applications,

نشانی: تهران - خیابان سعدی جنوبی - چهارراه اکباتان ناظم الاطبا شمالی - پلاک ۱۶۷

تلفن: ۳۳۵۳۲۶۰۲ - ۳۳۹۵۹۳۲۶ - ۳۳۵۳۲۱۹۴ - ۳۳۹۵۹۷۵۶ - ۳۳۹۵۹۷۵۶ - ۳۶۶۱۹۵۱۰ - ۳۶۶۱۹۳۹۰

such as small-to-large size CNC routers,CNC milling,plasmas,large-scale laser cutters/engravers,labeling equipment, robotics,gemstone processing machines, pick& place machines, X-Y tables

4 Specifications

4.1 Electrical Specifications

Parameter	Min	Typical	Max	Unit
Input Voltage (TS808C)	24	36/48/68	80	VDC
Output Current (Peak)	0.5	-	8	A
Pulse Input Frequency	0	-	150	kHz
Logic Signal Current	7	10	16	mA
Isolation Resistance	100	-	-	MΩ

4.2 Operating Environment

Cooling	Natural Cooling or Forced cooling	
Operating Environment	Environment	Avoid dust, oil fog and corrosive gases
	Storage Temperature	-20°C — 65°C (-4°F — 149°F)
	Ambient Temperature	0°C — 50°C (32°F — 122°F)
	Humidity	40%RH — 90%RH
	Operating Temperature (Heat Sink)	70°C (158°F) Max
	Weight	0.5k g

5 Mechanical Specifications

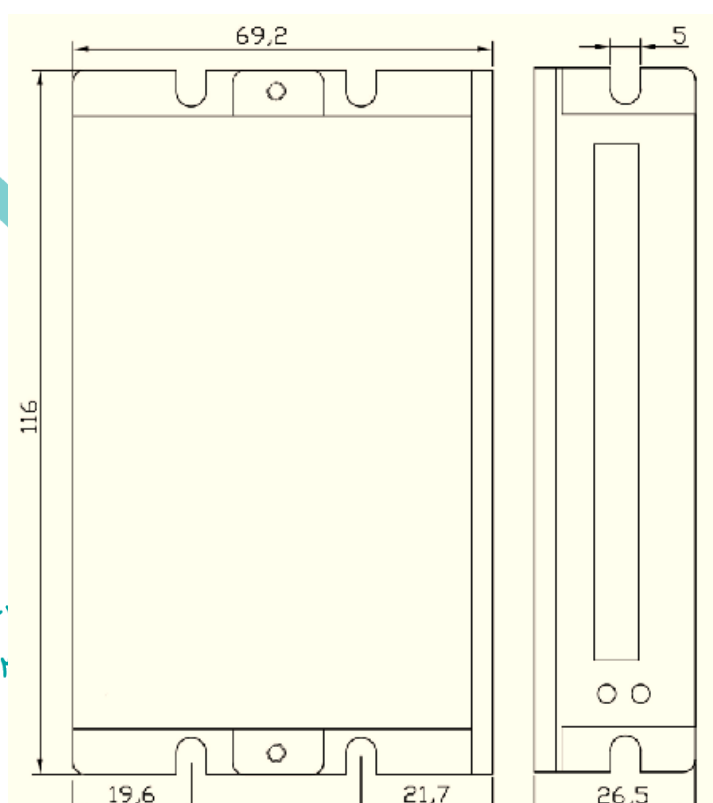

CN

TS

۱۶
۳۳۵۳۲۶۰۲ - ۳۲

نشانی: تهر
تلفن: ۰۳۶۶۱۹۳۹۰ - ۱۰

6 Connectors and Pin Assignment

The TS808C has four connectors, connector for control signals connections, connector for status signal connections, connector for encoder feedback and connector for power and motor connections

6.1 Control signals connector

Pin	Definition	I/O	Description
1	PUL+	I	Pulse Signal: In PUL+DIR(pulse/direction) mode, this input represents pulse signal, each rising or falling edge active (software configurable, see hybrid servo drive software manual for more detail); In CW+CCW mode (software configurable), this input represents clockwise (CW) pulse, active both at high level and low level. 4.5-28V when PUL-HIGH, 0-0.5V when PUL-LOW. For reliable response, pulse width should be longer than 2.0 μ s.
2	PUL-	I	
3	DIR+	I	Direction Signal: In PUL+DIR mode, this signal has low/high voltage levels, representing two directions of motor rotation. In CW+CCW mode (software configurable), this signal is counter-clock (CCW) pulse, active both at high level and low level. For reliable motion response, DIR signal should be ahead of PUL signal by 2 μ s at least. 4.5-28V when DIR-HIGH, 0-0.5V when DIR-LOW. Please note that rotation direction is also related to Motor driver encoder wiring match. Exchanging both the connection of two wires for a coil and an encoder channel to the driver he connection will reverse motion direction. Or you can toggle the SW5 to reverse the motion direction.
4	DIR-	I	
5	ENA+	I	Enable Signal: This signal is used for enabling/disabling the driver. In default, high level (NPN control signal) for enabling the driver and low level for disabling the driver. Usually left UNCONNECTED (ENABLED). Please note that PNP and Differential control signals are on the contrary, namely Low level for enabling. The active level of ENA signal is software configurable.
6	ENA-	I	

نشانی: تهران - خیابان سعدی جنوبی - چهارراه اکباتان ناظم الاطبا شمالی - پلاک ۱۶۷

تلفن : ۳۳۵۳۲۶۰۲ - ۳۳۹۵۹۳۲۶ - ۳۳۵۳۲۱۹۴ - ۳۳۹۵۹۷۵۶ - ۳۳۹۵۹۷۵۶ - ۳۶۶۱۹۵۱۰ - ۳۶۶۱۹۳۹۰

7	ALM+	O	ALM Signal: OC output signal, active when one of the following protection is activated: over-voltage, over current and position following error. This port can sink or source 70mA current at 24V. In default, the resistance between ALM+ and ALM- is low impedance in normal operation and become high when TS808C goes into error. The active level of alarm signal is software configurable.
8	ALM-	O	

6.2 Encoder Feedback Connector

Pin	Definition	I/O	Description
1	EB+	I	Encoder channel B+ input
2	EB-	I	Encoder channel B- input
3	EA+	I	Encoder channel A+ input
4	EA-	I	Encoder channel A- input
5	VCC	O	+5V @ 100 mA max.

6.3 Power and Motor

Pin	Definition	I/O	Description
1	A+	O	Motor Phase A+
2	A-	O	Motor Phase A-
3	B+	O	Motor Phase B+
4	B-	O	Motor Phase B-
5	+Vdc	I	20-80VDC recommended, leaving rooms for voltage fluctuation and back-EMF.
6	GND	GND	

6.4 RS232/RS485 Communication Port

It is used to configure the close-loop current, open-loop current, position following error limit and etc. See hybrid servo drive software operational manual for more information.

Pin	Definition	I/O	Description
1	+5V	-	+5V power only for STU (Simple Tuning Unit).
2	NC		
3	TxD	O	RS232 transmit.
4	GND	GND	Ground.
5	RxD	I	RS232 receive.
6	NC	-	Not connected.

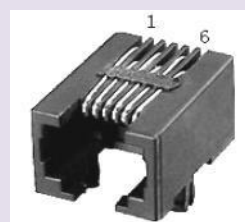

نشانی: تهران - خیابان سعدی جنوبی - چهارراه اکباتان ناظم الاطبا شمالی - پلاک ۱۶۷

تلفن: ۰۲۶۳۵۳۲۶ - ۳۳۹۵۹۳۲۶ - ۳۳۵۳۲۱۹۴ - ۳۳۹۵۹۷۵۶ - ۳۳۹۵۹۷۵۶ - ۳۶۶۱۹۵۱۰ - ۳۶۶۱۹۳۹۰

7 DIP Switch Settings

7.1 Microstep Revolution (SW1-SW4)

Steps/Revolution	SW1	SW2	SW3	SW4
Software Configured (Default 400)	on	on	on	on
800	off	on	on	on
1600	on	off	on	on
3200	off	off	on	on
6400	on	on	off	on
12800	off	on	off	on
25600	on	off	off	on
51200	off	off	off	on
1000	on	on	on	off
2000	off	on	on	off
4000	on	off	on	off
5000	off	off	on	off
8000	on	on	off	off
10000	off	on	off	off
20000	on	off	off	off
40000	off	off	off	off

7.2 Motor Direction (SW5) and Mode sel (SW6)

	Function	On	Off
SW5	Default <small>Note</small>	CW (clock-wise)	CCW (counter-clock-wise)
SW6	Mode Sel	PM	FOC

Note: You can toggle SW5 to change the motor direction.

SW6: it is function mode setting

ON is PM mode(position to position mode),this mode is good performance for start and stop

OFF is vector control mode

7.3 Motor Sel (SW7-SW8)

Motor Sel	SW7	SW8
EC42	on	on
EC57	off	on

نشانی: تهران - خیابان سعدی جنوبی - چهارراه اکباتان ناظم الاطبای شمالی - پلاک ۱۶۷

تلفن: ۰۲۰۳۳۵۳۲۶ - ۳۳۹۵۹۳۲۶ - ۳۳۵۳۲۱۹۴ - ۳۳۹۵۹۷۵۶ - ۳۳۹۵۹۷۵۶ - ۳۶۶۱۹۵۱۰ - ۳۶۶۱۹۳۹۰

<https://shop.cncparts.ir>

EC60	on	off
EC86	off	off

7.4 Current Control

The motor current will be adjusted automatically regarding to the load or the stator-rotor relationship. However, the user can also configure the current in the tuning software. The configurable parameters include close-loop current, holding current, encoder resolution, micro step and etc. There are also PID parameters for the current loop, and they have been tuned for JKON-TEK technology's matching motors so the user does not need to tune them.

8 Hybrid servo Motors

TS808C can work with the following JKON-TEK technology's hybrid servo motors:

8.1 Nema17 hybrid servo motors

	EC42-03	EC42-04
Step Angle (Degree)	1.8	1.8
Holding Torque (N.m)	0.3	0.4
Phase Current (A)	2.3	2.3
Phase Resistance (Ohm)	0.9	1.1
Phase Inductance (mH)	1.66	1.7
Inertia (g.cm ²)	57	62
Weight (Kg)	0.24	0.32
Encoder (lines / Rev.)	1000	1000

	EC42-06	EC42-08
Step Angle (Degree)	1.8	1.8
Holding Torque (N.m)	0.6	0.8
Phase Current (A)	2.3	2.3
Phase Resistance (Ohm)	1.3	1.74
Phase Inductance (mH)	2.3	4.2
Inertia (g.cm ²)	86	1.2
Weight (Kg)	0.45	0.50
Encoder (lines / Rev.)	1000	1000

8.2 Nema23 hybrid servo motors

	EC57-10	EC57-22	EC57-28
--	---------	---------	---------

نشانی: تهران - خیابان سعدی جنوبی - چهارراه اکباتان ناظم الاطبای شمالی - پلاک ۱۶۷

تلفن: ۳۳۵۳۲۶۰۲ - ۳۳۹۵۹۳۲۶ - ۳۳۵۳۲۱۹۴ - ۳۳۹۵۹۷۵۶ - ۳۳۹۵۹۷۵۶ - ۳۶۶۱۹۵۱۰ - ۳۶۶۱۹۳۹۰

Step Angle (Degree)	1.8	1.8	1.8
Holding Torque (N.m)	1.1	2.4	2.8
Phase Current (A)	6.0	6.0	13.0
Phase Resistance (Ohm)	0.2	0.4	0.2
Phase Inductance (mH)	0.52	1.5	0.36
Inertia (g.cm2)	0.30	0.48	0.58
Weight (Kg)	0.7	1.1	1.5
Encoder (lines / Rev.)	1000	1000	1000

8.3 Nema24 hybrid servo motors

	EC60-15	EC60-30
Step Angle (Degree)	1.8	1.8
Holding Torque (N.m)	1.5	3.6
Phase Current (A)	6.0	6.0
Phase Resistance (Ohm)	0.6	0.7
Phase Inductance (mH)	1.8	1.9
Inertia (g.cm2)	0.84	0.91
Weight (Kg)	1.1	1.4
Encoder (lines / Rev.)	1000	1000

8.4 Nema34 hybrid servo motors

	EC86-45	EC86-85	EC86-120
Step Angle (Degree)	1.8	1.8	1.8
Holding Torque (N.m)	4.5	8.5	12
Phase Current (A)	6.0	6.0	6.0
Phase Resistance (Ohm)	0.325	0.5	0.73
Phase Inductance (mH)	3	6.0	8.68
Inertia (g.cm2)	1.4	2.7	4000
Weight (Kg)	2.3	3.8	5.3
Encoder (lines / Rev.)	1000	1000	1000

8.5 Motor Encoder Cable Connector

Pin	Name	I/O	Description
1	EA+	O	Phase A+
2	VCC	I	+5V power input
3	GND		Ground
11	EB+	O	Phase B+



HDD15 Male

نشانی: تهران - خیابان سعدی جنوبی - چهارراه اکباتان ناظم الاطبای شمالی - پلاک ۱۶۷

تلفن: ۰۲-۳۳۵۳۲۶۰۳ - ۳۳۹۵۹۳۲۶ - ۳۳۵۳۲۱۹۴ - ۳۳۹۵۹۷۵۶ - ۳۳۹۵۹۷۵۶ - ۳۶۶۱۹۵۱۰ - ۳۶۶۱۹۳۹۰

12	EB-	O	Phase B-
13	EA-	O	Phase A-

8.6 Motor Encoder Extension Cable

Pin Assignments

Pin	Wire Color	Definition	Description	Pin	Wire Color	Definition	Description
2	RED	VCC	+5V power input	12	BLK	EB-	phase B-
3	WHT	EGND	+5V GND	1	BLU/WHT	EA+	phase A+
11	BLK/WHT	EB+	Channel B+	13	BLU	EA-	phase A-

9 Wiring Diagrams

9.1 Interface

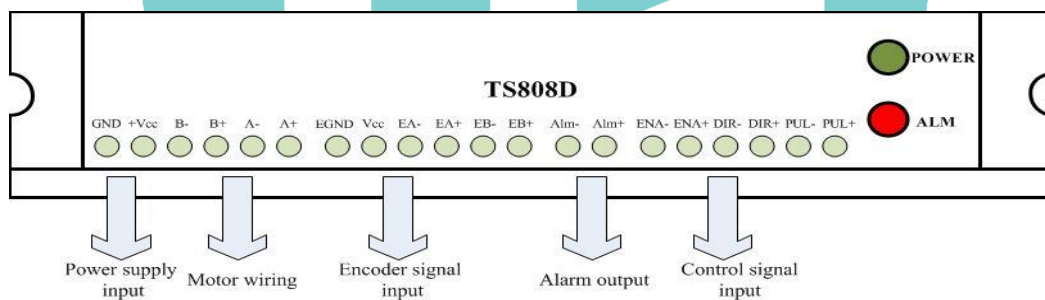

9.2 Diagram

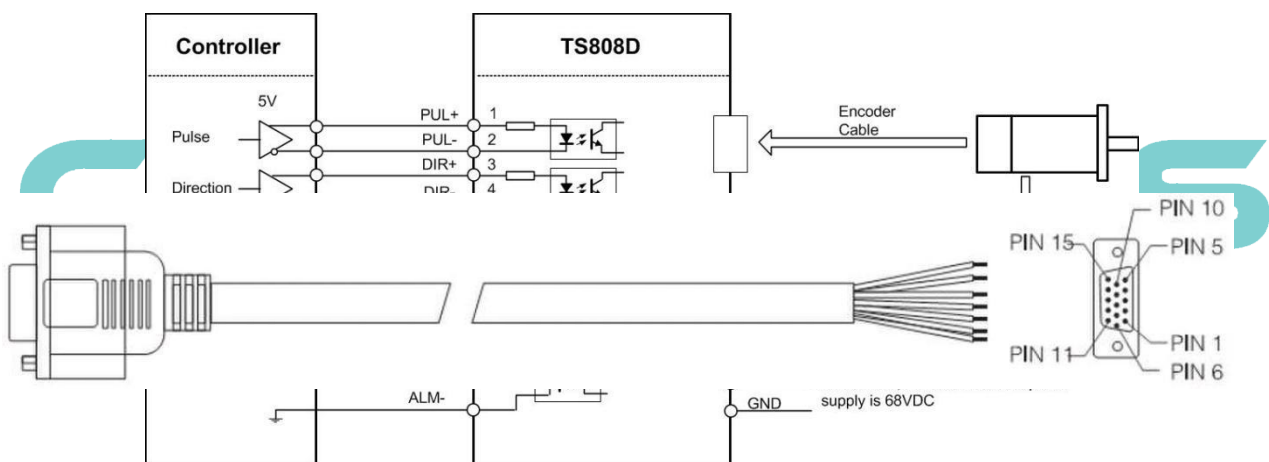

نشانی: تهران - خیابان سعدی جنوبی - چهارراه اکباتان ناظم الاطبا شمالی - پلاک ۱۶۷

تلفن: ۳۳۵۳۲۶۰۲ - ۳۳۹۵۹۳۲۶ - ۳۳۵۳۲۱۹۴ - ۳۳۹۵۹۷۵۶ - ۳۳۹۵۹۷۵۶ - ۳۶۶۱۹۵۱۰ - ۳۶۶۱۹۳۹۰

9.3 Control Signal Wiring

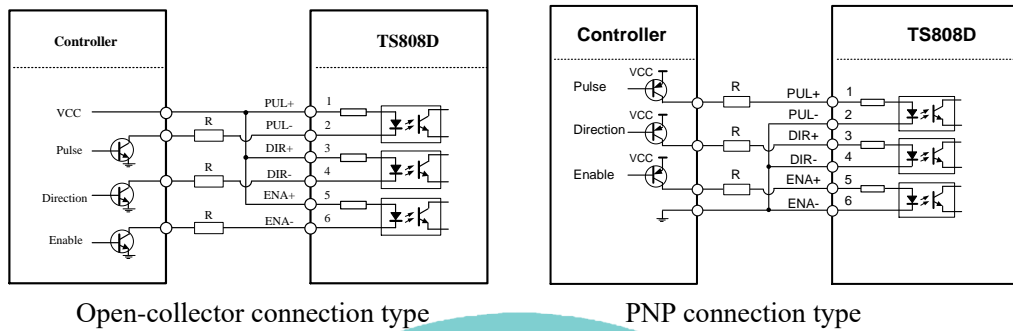

Wiring Notes

- ✧ In order to improve anti-interference performance of the drive, it is recommended to use twisted pair shield cable.
- ✧ To prevent noise incurred in PUL/DIR signal, pulse/direction signal wires and motor wires should not be tied up together. It is better to separate them by at least 10 cm, otherwise the disturbing signals generated by motor will easily disturb pulse direction signals, causing motor position error, system instability and other failures.
- ✧ If a power supply serves several drives, separately connecting the drives is recommended instead of daisy-chaining.
- ✧ It is prohibited to pull and plug power connector while the drive is powered ON, because there is high current flowing through motor coils (even when motor is at standstill). Pulling or plugging power connector with power on will cause extremely high back-EMF voltage surge, which may damage the drive.

10 Protection Indications

The green indicator turns on when power-up. When drive protection is activated, the red LED blinks periodically to indicate the error type.

Priority	Time(s) of Blink	Sequence wave of RED LED	Description
1st	1		Over-current protection
2nd	2		Over-voltage protection
3rd	7		Position Following Error

11 Frequently Asked Questions

In the event that your drive doesn't operate properly, the first step is to identify whether the problem is electrical or mechanical in nature. The next step is to isolate the system component that is causing the problem. As part of this process you may have to disconnect the individual components that make up your system and verify that they

نشانی: تهران - خیابان سعدی جنوبی - چهارراه اکباتان ناظم الاطبا شمالی - پلاک ۱۶۷

تلفن : ۳۳۵۳۲۶۰۲ - ۳۳۹۵۹۳۲۶ - ۳۳۵۳۲۱۹۴ - ۳۳۹۵۹۷۵۶ - ۳۳۹۵۹۷۵۶ - ۳۶۶۱۹۵۱۰ - ۳۶۶۱۹۳۹۰

operate independently. It is important to document each step in the troubleshooting process. You may need this documentation to refer back to at a later date, and these details will greatly assist our Technical Support staff in determining the problem should you need assistance.

Many of the problems that affect motion control systems can be traced to electrical noise, controller software errors, or mistake in wiring.

Problem Symptoms and Possible Causes

Symptoms	Possible Problems
Motor is not rotating	No power
	Micro-step resolution setting is wrong
	Fault condition exists
	The drive is disabled
	The wiring is wrong
The drive In alarm	Power supply is over voltage
	Something wrong with motor coil
Wrong motor motion	Control signal is too weak
	Control signal is interfered
	Something wrong with motor coil
	Power supply voltage too low
Motor or drive is too heating	Inadequate heat sinking / cooling
	Load is too heavy

12 Warranty

Shenzhen JKON-TEK Technology Co., Ltd. warrants its products against defects in materials and workmanship for a period of 12 months from shipment out of factory. During the warranty period, JKON-TEK technology will either, at its option, repair or replace products which proved to be defective.

Exclusions

The above warranty does not extend to any product damaged by reasons of improper or inadequate handlings by customer, improper or inadequate customer wirings, unauthorized modification or misuse, or operation beyond the electrical specifications of the product and/or operation beyond environmental specifications for the product.

Obtaining Warranty Service

To obtain warranty service, a returned material authorization number (RMA) must be obtained from customer service at e-mail: technical01@hybridservo.com before returning product for service. Customer shall prepay shipping charges for products returned to JKON-TEK technology for warranty service, and JKON-TEK technology shall pay for return of products to customer.

Warranty Limitations

JKON-TEK technology makes no other warranty, either expressed or implied, with respect to the product.

نشانی: تهران - خیابان سعدی جنوبی - چهارراه اکباتان ناظم الاطبا شمالی - پلاک ۱۶۷

تلفن : ۳۳۵۳۲۶۰۲ - ۳۳۹۵۹۳۲۶ - ۳۳۵۳۲۱۹۴ - ۳۳۹۵۹۷۵۶ - ۳۳۹۵۹۷۵۶ - ۳۶۶۱۹۵۱۰ - ۳۶۶۱۹۳۹۰

<https://shop.cncparts.ir/>

JKON-TEK technology specifically disclaims the implied warranties of merchantability and fitness for a particular purpose. Some jurisdictions do not allow limitations on how long and implied warranty lasts, so the above limitation or exclusion may not apply to you. However, any implied warranty of merchantability or fitness is limited to the 12-month duration of this written warranty.

Contact us:

Shenzhen JKON-TEK Technology Co.,Ltd

Address: 2F, Building B, Jintai Industrial Park, Hangcheng Avenue, Gushu Village, Xixiang Street, Bao'an Area, Shenzhen City, Guangdong Province, China

Tel: +86 136 2096 1024

Sales: enquiry@hybridservo.com

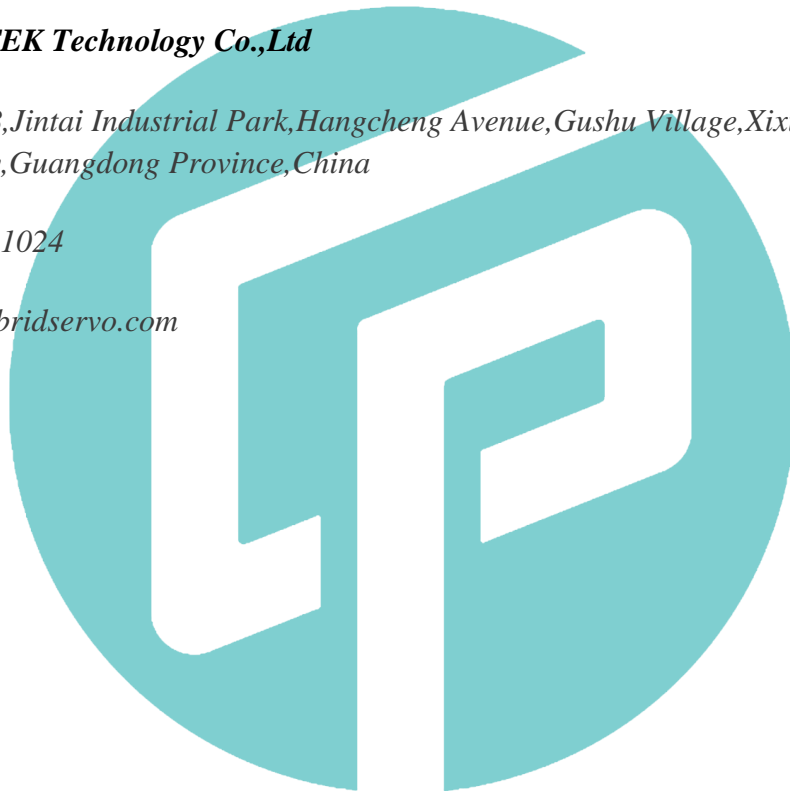

CNC PARTS

نشانی: تهران - خیابان سعدی جنوبی - چهارراه اکباتان ناظم الاطبا شمالی - پلاک ۱۶۷

تلفن: ۳۳۵۳۲۶۰۲ - ۳۳۹۵۹۳۲۶ - ۳۳۵۳۲۱۹۴ - ۳۳۹۵۹۷۵۶ - ۳۳۹۵۹۷۵۶ - ۳۶۶۱۹۵۱۰ - ۳۶۶۱۹۳۹۰

<https://shop.cncparts.ir>