

**HQD®**

**五轴加工中心  
水冷自动换刀主轴**

WOODWORKING WITH WATER-COOLED SPINDLE

常州市高新技术产品认定证书

**HQD®**

**九垂直  
数控排钻**

NINE VERTICAL CNC BORING HEAD

常州市高新技术产品认定证书

**产品介绍**

该主轴为水冷自动换刀电主轴。可用于有色金属、轻合金、复合材料、塑料、木材等具有类似物理特性材料的加工机床。紧凑的机器设计，极小的旋转体积，可搭载在五轴专用的A/C双摆头上实现多轴联动，广角旋转最大程度覆盖加工区域，特别适合于轮廓及型腔复杂的各类模具加工。刀具接口符合DIN 69893标准的HSK刀柄安装，连接刚性好，适宜高转速运行，可适应长刀杆的精加工工况。配置松拉刀及轴停止检测传感器及过热保护温控开关，保证主轴安全可靠运行。

**PRODUCTS**

The main shaft is a water-cooled automatic tool changing electric spindle. It can be used for processing machine tools of non-ferrous metals, light alloys, composite materials, plastics, wood and other materials with similar physical properties. Compact machine design, small volume of rotation, can be carried on the five-axis dedicated A/C double swing head to achieve multi-axis linkage, wide-angle rotation to maximize the coverage of the processing area, especially suitable for all kinds of mold processing with complex profile and cavity. The tool interface is in line with HSK tool handle installation of DIN 69893 standard, with good connection rigidity, suitable for high speed operation, and can adapt to the finishing conditions of long tool bar. Equipped with loosening tool, shaft stop detection sensor and overheat protection temperature control switch to ensure the safe and reliable operation of the spindle.

**技术参数 TECHNICAL DATA**

主轴型号 Spindle type	电机 Motor						轴端连接 Joint of nose	冷却 Cool	润滑 Lub	轴承型号 Bearings type	备注	重量 Kg
	转速 (r/min)	额定功率 KW	电压 V	电流 A	频率 Hz	极数 P						
GDL65-HSK63F-24Z/12-4	24000	12	380	26	800	4	HSK63F	水冷	油脂	2X7010CP4 2X7006CP4	带传感器 拉刀结构	17
GDL65-ISO30-18Z/9-4	13500-18000	9	380	20	450-600	4	ISO30	水冷	油脂	2X7010CP4 2X7006CP4	带传感器 拉刀结构	18

说明：产品和规格如有更新时，将不另行通知，请以实物为准。

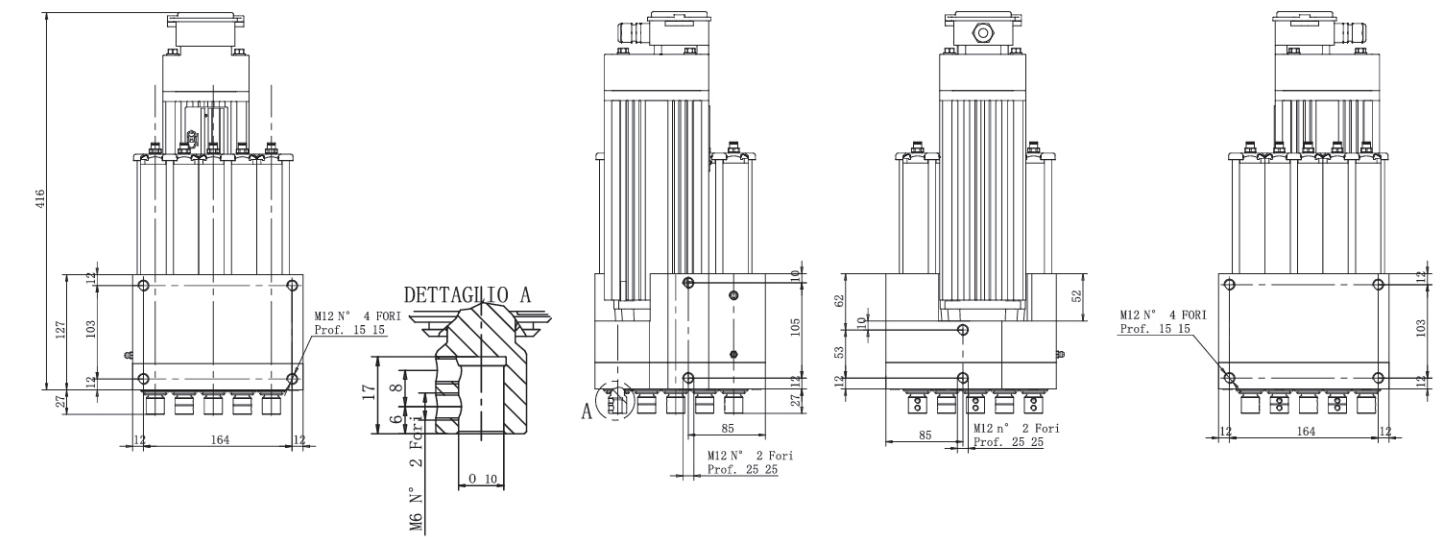
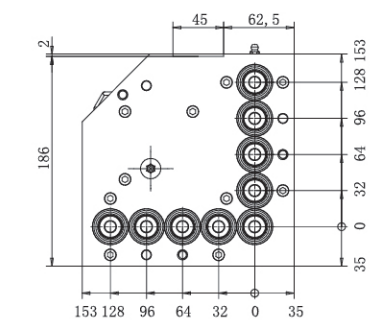
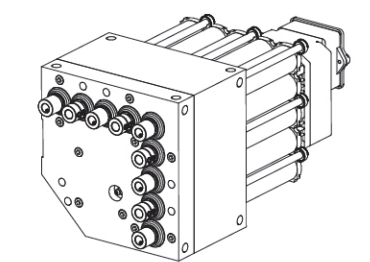

Boring Head For Wood Working		CE
Type:CNC-9		
Technical and Operating Characteristics		
Working Environment Temperatur	5°C-40°C	CE
Feed air Pressure	7-9bar	
Lubrication gear	ISO FLEX TOPAS Nb52	SGS ISO 9001:2008
N°Vertical Spiandles Tot	9	
N°Vertical Spiandles -X	5	
N°Vertical Spiandles -Y	4	
Tools coupling	Φ 10	
Center Hole Distance	32mm	
Vertical spindles speed	3200RPM	



# 3X3 数控排钻 (六面钻下钻)

3X3CNC  
BORING  
HEAD

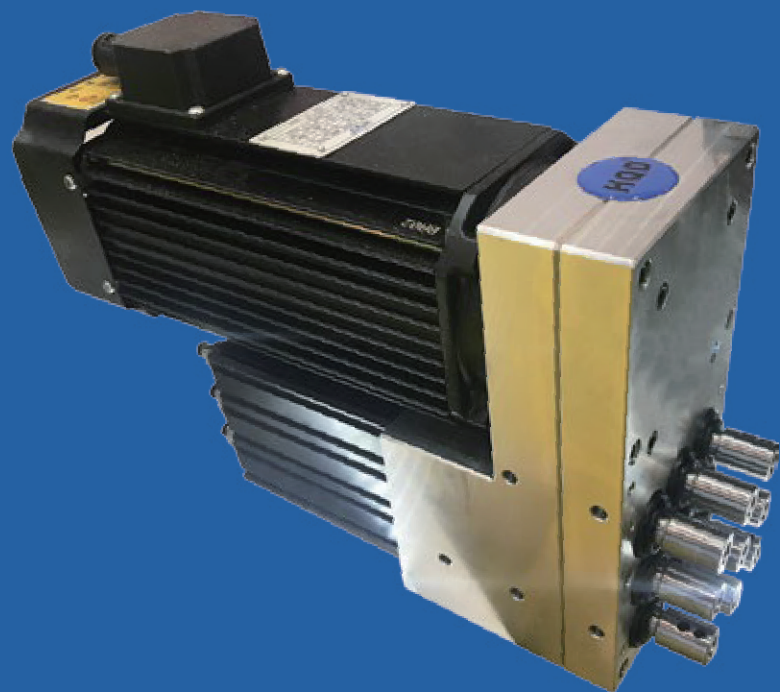

# 12+4 数控排钻 (6面钻上 钻左右侧)

CNC  
DRILLING  
HOLES

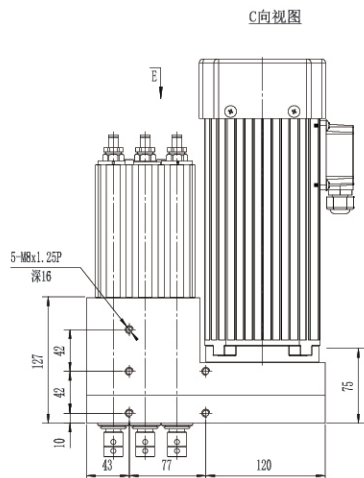
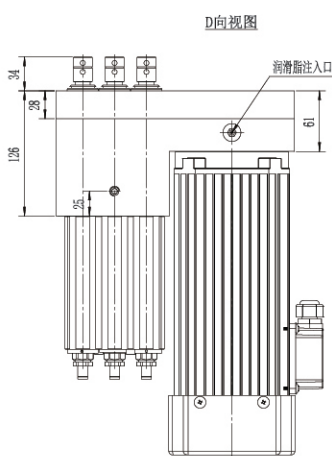
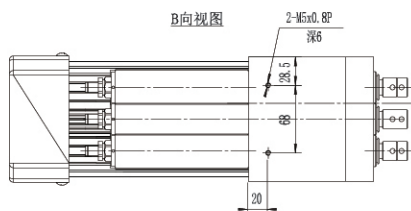
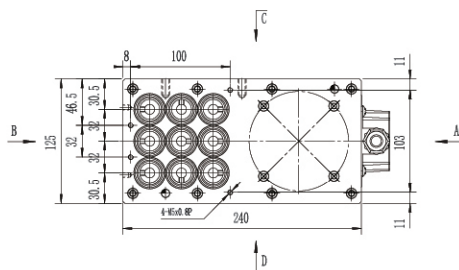
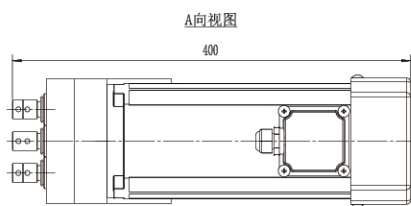
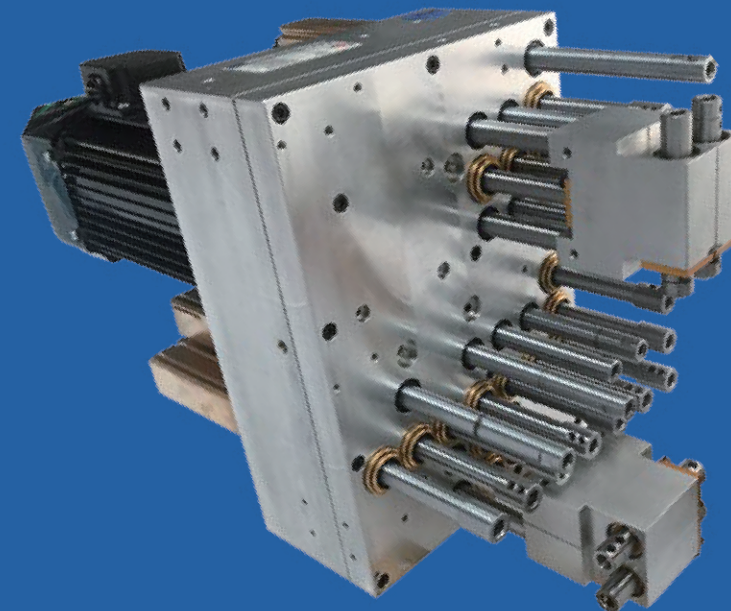

E向视图

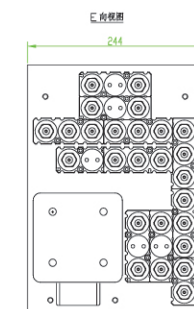
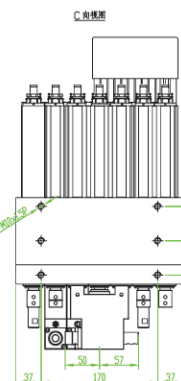
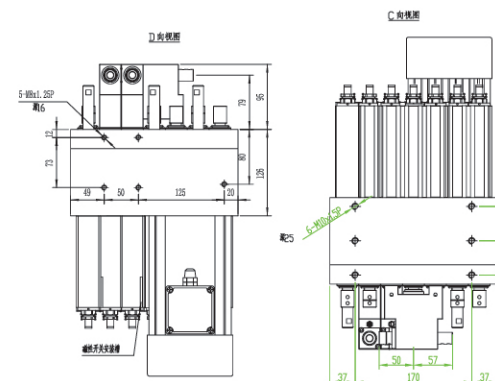
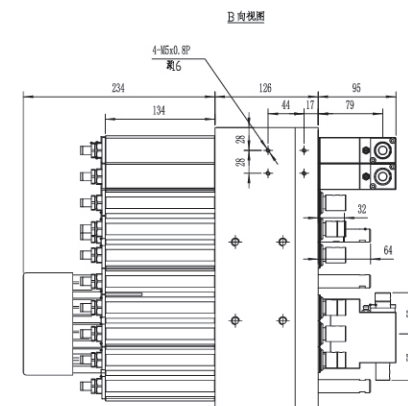
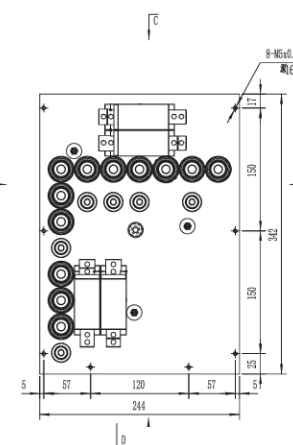
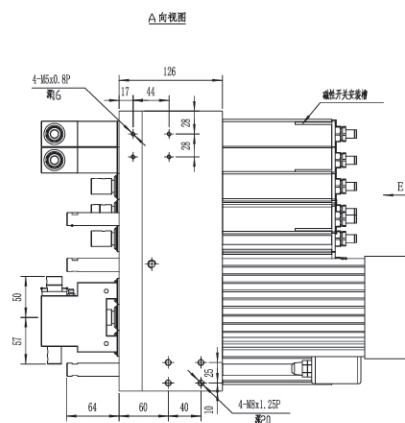
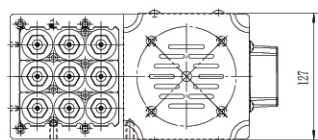

<b>HQP®</b> Boring Head For Wood Working Type:CNC-V3X3		<b>CE</b>
Technical and Operating Characteristics		
Working Environment Temperature	5°C-40°C	<b>SGS</b>
Feed Air Pressure	7-9bar	
Lubrication Gear	ISO FLEX TOPAS L32N	
Vertical Gear Shaft	9	
Arrangement Mode	3X3	
Air Cylinder Move Range	58mm	
Tools Coupling	Ø10	
Center Hole Distance	32mm	
Vertical Spindles Speed	4500RPM	

<b>HQP®</b> Boring Head For Wood Working Type:CNC-V12H4L/R		<b>CE</b>	
Technical and Operating Characteristics			
Working Environment Temperature	5°C-40°C		<b>SGS</b>
Feed air Pressure	7.5 bar		
Center Hole Distance	32mm		
Drive Motor Ramp-up Speed	0-Rpm max>2s		
Vertical Spindle Stroke	68mm		
Horizontal Spindle Stroke	68mm		
Rpm Vertical Spindle	4500 max		
Vertical Spindle's Tool Housing	Ø10mm		
Rpm Horizontal Spindle	4500 max		
Horizontal Spindle's Tool Housing	Ø10mm		
Type of Lubrication	grease		
Lubricant Model	ISO FLEX TOPAS L32N		



加工中心  
水冷自动  
换刀主轴

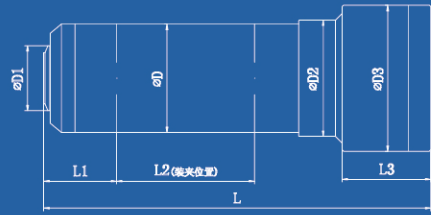

### 技术参数 TECHNICAL DATA

主轴型号 Spindle type	电机 Motor							轴端连接 Joint of nose	润滑 Lub	冷却 Cool	轴承型号 Bearings type	备注 Remark 带传感器及松拉刀机构
	转速 (r/min)	额定功率 KW	扭矩 Nm	电压 V	电流 A	频率 Hz	极数 PI					
GDL80-20-24Z/1.5	24000	1.5	0.60	220	5.6	400	2	ISO20 锥孔	油脂 Grease	水冷 Cool	2X7005C P4 1X7004C P4	带传感器及松拉刀机构
GDL80-20-24Z/1.5	24000	1.5	0.60	220	5.8	800	4	ISO20 锥孔	油脂 Grease	水冷 Cool	2X7005C P4 1X7004C P4	带传感器及松拉刀机构
GDL80-20-24Z/2.2		2.2	0.88		7.6							
<b>GDL80-20-24Z/2.2</b>	24000	2.2	<b>0.72</b>	220	<b>7.6</b>	400	2	ISO20 锥孔	油脂 Grease	水冷 Cool	2X7005C P4 1X7004C P4	带传感器及松拉刀机构
GDL80-20-30Z/1.5	30000	1.5	0.50	220	5.8	1000	4	ISO20 锥孔	油脂 Grease	水冷 Cool	2XHY6005C P4 1X7005C P4	带传感器及松拉刀机构
GDL80-20-30Z/2.2		2.2	0.70		7.6							
GDL100-25-24Z/2.5	24000	2.5	1.00	220 380	9.20 5.50	400	2	ISO25 锥孔	油脂 Grease	水冷 Cool	2X7006C P4 1X7005C P4	带传感器及松拉刀机构
GDL110-30-18Z/3.2	18000	3.2	1.70	220 380	11.5 6.90	600	4	BT30 锥孔	油脂 Grease	水冷 Cool	2X7007C P4 1X7005C P4	带传感器及松拉刀机构
GDL110-30-24Z/4.5	24000	4.5	1.79	220 380	15.5 9.20	800	4	BT30 锥孔	油脂 Grease	水冷 Cool	2XSM6007C P4 1X7005C P4	带传感器及松拉刀机构
GDL120-30-18Z/5.5	18000	5.5	2.65	380	11.0	600	4	BT30 锥孔	油脂 Grease	水冷 Cool	2X7008C P4 2X7006C P4	带传感器及松拉刀机构
<b>GDL120-30-24Z/5.5</b>	24000	5.5	2.19	220 380	19.0 11.0	800	4	BT30 锥孔	油脂 Grease	水冷 Cool	2X7008C P4 2X7006C P4	带传感器及松拉刀机构
GDL120-30-24Z/6.5	24000	6.5	2.60	380	13.5	800	4	BT30 锥孔	油脂 Grease	水冷 Cool	2XSM6008C P4 2XSM6006C P4	带传感器及松拉刀机构
GDL125-30-18Z/7.5	18000	7.5	3.98	380	16.5	600	4	BT30 锥孔	油脂 Grease	水冷 Cool	2X7008C P4 2X7006C P4	带传感器及松拉刀机构
<b>GDL125-30-24Z/7.5</b>	24000	7.5	2.98	380	15	800	4	BT30 锥孔	油脂 Grease	水冷 Cool	2X7008C P4 2X7007C P4	带传感器及松拉刀机构
GDL125-40-12Z/7.5	12000	7.5	5.98	380	16.5	600	6	BT40 锥孔	油脂 Grease	水冷 Cool	2X7011C P4 2X7008C P4	带传感器及松拉刀机构
GDL150-40-12Z/12	12000	12.0	9.55	380	25.0	400	4	BT40 锥孔	油脂 Grease	水冷 Cool	2XSM6011C P4 2X7008C P4	带传感器及松拉刀机构
GDL110-30-18Z/3.2	18000	3.2	1.70	220 380	11.5 6.90	600	4	BT30 锥孔	油脂 Grease	水冷 Cool	2XSM6007C P4 1X7005C P4	带传感器及松拉刀机构
GDL120-30-18Z/5.5	18000	5.5	2.65	380	11.0	600	4	BT30 锥孔	油脂 Grease	水冷 Cool	2X7008C P4 2X7006C P4	带传感器及松拉刀机构
GDL120-30-24Z/6.5	24000	6.5	2.6	380	13.5	800	4	BT30 锥孔	油脂 Grease	水冷 Cool	2XSM6008C P4 2XSM6006C P4	带传感器及松拉刀机构
GDL150-40-12Z/7.5	12000	7.5	5.98	380	16.5	400	4	BT40 锥孔	油脂 Grease	水冷 Cool	2XSM6011C P4 2X7008C P4	带传感器及松拉刀机构
GDL150-40-12Z/12	12000	12.0	9.55	380	25.0	400	4	BT40 锥孔	油脂 Grease	水冷 Cool	2XSM6011C P4 2X7008C P4	带传感器及松拉刀机构
GDL170-40-10Z/14	10000	14.0	13.38	380	28.0	334	4	BT40 锥孔带键	油脂 Grease	水冷 Cool	2XSM6014C P4 2X7010C P4	带编码器、传感器及松拉刀机构

说明：产品和规格如有更新时，将不另行通知，请以实物为准。



加工中心  
水冷自动  
换刀主轴

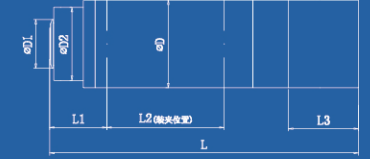
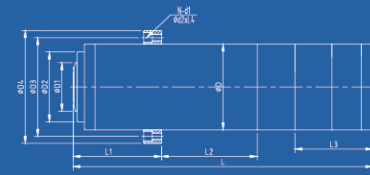

### 技术参数 TECHNICAL DATA

主轴型号 Spindle type	外形尺寸 Dimensions(mm)											重量 kg
	ØD	ØD1	ØD2	ØD3	ØD4	L	L1	L2	L3	N-d1	Ød2XL4	
GDL80-20-24Z/1.5	80	48	—	—	—	353	60	125	102	—	—	9
GDL80-20-24Z/1.5	80	48	86	108	—	286.5	60	100	65.5	—	—	8
GDL80-20-24Z/2.2												
GDL80-20-24Z/2.2	80	48	—	—	—	353	60	125	102	—	—	9
GDL80-20-30Z/1.5	80	48	86	108	—	286.5	60	98	65.5	—	—	8
GDL80-20-30Z/2.2												
GDL100-25-24Z/2.5	100	58	78	—	—	393	76	130	110	—	—	18
GDL110-30-18Z/3.2	110	63	90	—	—	398.5	80	132	110	—	—	23
GDL110-30-24Z/4.5	110	63	90	—	—	398.5	80	132	110	—	—	19
GDL120-30-18Z/5.5	120	68	98	—	—	424	86	136	110	—	—	25
GDL120-30-24Z/5.5	120	68	98	—	—	424	86	136	110	—	—	25
GDL120-30-24Z/6.5	120	68	98	—	—	424	86	136	110	—	—	25
GDL125-30-18Z/7.5	125	66	98	—	—	464	88	172	110	—	—	34
GDL125-30-24Z/7.5	125	66	98	—	—	464	88	172.5	110	—	—	30
GDL125-40-12Z/7.5	125	83	—	—	—	538.5	99	172	110	—	—	34
GDL150-40-12Z/12	150	83	125	—	—	530.5	103	190	120	—	—	49
*GDL110-30-18Z/3.2	110	63	110	135	152	430.5	125	112	110	6-Ø7.0	Ø11X12	24
*GDL120-30-18Z/5.5	120	68	98	138	158	424	125	135.5	110	6-Ø9.0	Ø14X12	24
*GDL120-30-24Z/6.5	120	68	98	138	158	424	125	135.5	110	6-Ø9.0	Ø14X12	26
*GDL150-40-12Z/7.5	150	83	125	165	185	505.5	81	244	120	6-Ø8.5	Ø14X8.5	47
*GDL150-40-12Z/12	150	83	125	165	185	530.5	81	269	120	6-Ø8.5	Ø14X8.5	50
*GDL170-40-10Z/14	170	68	150	185	205	638.5	123	293.5	122.5	8-Ø8.5	Ø14X8.5	75

说明：产品和规格如有更新时，将不另行通知，请以实物为准。  
\* 为带法兰主轴。

**HQD®**

# 超声波电主轴

ULTRASONIC ELECTRICAL SPINDLE

发明专利证书

水冷却 油脂润滑

## 产品介绍

GDC 系列超声波电主轴是我公司拥有自主知识产权的新一代产品。超声波主轴工作频率 35-50KHz，振幅 ≥ 20um(可调)，最大输出功率 60w。其利用刀具在轴向高频振动，以及刀具高速旋转切削工件等多重作用下，可以减少加工阻力，提高加工效率，明显提高加工面品质，刀具因本身高频振动而不沾残屑，极大延长刀具使用寿命，残留加工应力小等优势。适合强化玻璃，陶瓷，玉石，蓝宝石，硬质合金，半导体等零件加工以及石英、氧化铝等硬脆材料的加工。

## PRODUCTS

GDC serial ultrasonic electrical spindle is the new generation product with independent intellectual property rights. It applies the ultrasonic rotating machining system to decrease machining resistance, increase machining efficiency, and improve the quality of finished surface under the multiple effects of high-frequency vibration in axial direction and the high-speed rotary cutting tool. And the tool itself shall not be stained with any residuals because of high-frequency vibration, which tremendously increase the service life of tools, and brings the advantage of small residual machining stress. It is suitable for the component machining of reinforced glass, ceramics, jade, sapphire, cemented carbide and semiconductor, etc., and also suitable for the numerical control precision machining of hard and brittle materials, such as deep-hole, micro-hole and hardened steel.

## 技术参数 TECHNICAL DATA

主轴型号 Spindle type	电机 Motor						外形尺寸 Dimensions (mm)					轴端连接 Joint of nose	润滑 Lub	冷却 Cool	轴承型号 Bearings type	重量 kg
	转速 (r/min)	额定功率 KW	电压 V	电流 A	频率 Hz	极数 Pl	L	L1	L2	L3	ØD					
GDC65-15Z/0.8	15000	0.8	220	3.0	250	2	328	20.5	65	110	65	ER11-Ø3.0-Ø7.0	油脂 Grease	水冷 Cool	2X7906C P4 2X7002C P4	6
GDC80-12Z/1.5	12000	1.5	220	5.8	400	4	549	29.5	57	95	80	ER16A-Ø3.0-Ø10	油脂 Grease	水冷 Cool	2X7907C P4 2X7003C P4	21
GDC110-30-12Z/3.7	12000	3.7	380	8.0	400	4	468	135	140	110	110	BT30 锥孔 带传感器及松拉力机构	油脂 Grease	水冷 Cool	2X7008C P4 1X7005C P4	27

说明：产品和规格如有更新时，将不另行通知，请以实物为准。

**HQD®**

# 恒功率电主轴

PERMANENT POWER SPINDLE

常州市高新技术产品认定证书

恒功率 水冷却 油脂润滑

## 技术参数 TECHNICAL DATA

主轴型号 Spindle type	电机 Motor							外形尺寸 Dimensions (mm)					轴端连接 Joint of nose	润滑 Lub	冷却 Cool	轴承型号 Bearings type	重量 kg
	转速 (r/min)	额定功率 KW	扭矩 Nm	电压 V	电流 A	频率 Hz	极数 Pl	L	L1	L2	ØD	ØD1					
GDK80-12-24Z/1.2-2.4	12000-24000	1.2	0.96-0.48	156-220	6.4	400-800	4	284	26	15	80	78	ER20-Ø3.175-Ø13	油脂 Grease	水冷 Cool	2X7005C P4 2X7002C P4	8
GDK100-12-24Z/2.4-4.4	12000-24000	2.2	1.75-0.88	269-380	6.8	400-800	4	295	27.5	30.5	100	78	ER20-Ø3.175-Ø13	油脂 Grease	水冷 Cool	2X7005C P4 2X7003C P4	12
GDK105-9-21Z/2.2-5.0	9000-21000	2.2	2.33-1.00	249-380	6.0	150-350	2	344	29	55	105	80	ER20-Ø3.175-Ø13	油脂 Grease	水冷 Cool	2X7006C P4 2X7004C P4	15.5
GDK110-9-21Z/2.2-5.0	9000-21000	2.2	2.33-1.17	249-380	6.0	150-350	2	352.5	30	62.5	110	85	ER25-Ø3.175-Ø16	油脂 Grease	水冷 Cool	2X7007C P4 2X7004C P4	16
GDK110-9-18Z/2.2-4.4	9000-18000	2.2	2.33-1.17	249-380	6.0	150-300	2	352.5	30	62.5	110	85	ER25-Ø3.175-Ø16	油脂 Grease	水冷 Cool	2X7007C P4 2X7004C P4	17.5
GDK120-9-18Z/4.0-8.0	9000-18000	4.0	4.24-2.12	269-380	12.5	450-900	6	365	29	59.5	120	94	ER25-Ø3.175-Ø16	油脂 Grease	水冷 Cool	2X7007C P4 2X7005C P4	23
GDK120-9-18Z/5.5-11	9000-18000	5.5	5.84-2.92	269-380	15.5	450-900	6	395	29	59.5	120	94	ER25-Ø3.175-Ø16	油脂 Grease	水冷 Cool	2X7007C P4 2X7005C P4	24
GDK125-12-24Z/4.0-8.0	12000-24000	4.0	3.18-1.59	380-380	8.9	200-400	2	365	32.5	56	125	100	ER25-Ø3.175-Ø16	油脂 Grease	水冷 Cool	2X7007C P4 2X7005C P4	25
GDK125-9-18Z/4.0-8.0	9000-18000	4.0	4.24-2.12	269-380	12.5	450-900	6	365	29	59.5	125	100	ER25-Ø3.175-Ø16	油脂 Grease	水冷 Cool	2X7007C P4 2X7005C P4	22
GDK125-9-18Z/5.5-11	9000-18000	5.5	5.84-2.92	269-380	15.5	450-900	6	395	29	59.5	125	100	ER25-Ø3.175-Ø16	油脂 Grease	水冷 Cool	2X7007C P4 2X7005C P4	31
GDK125-9-15Z/5.5-11	9000-15000	5.5	5.84-3.50	294-380	14.0	450-750	6	405	35	63.5	125	100	ER32-Ø3.175-Ø20	油脂 Grease	水冷 Cool	2X7009C P4 2X7005C P4	31
GDK125-12-24Z/7.5	12000-24000	7.5	5.96-2.98	380-380	15.0	400-800	4	404.5	36.5	53.5	125	92	ER32-Ø3.175-Ø20	油脂 Grease	水冷 Cool	2X7008C P4 2X7006C P4	28
GDK150-6-12Z/5.5-11	6000-12000	5.5	8.75-4.38	269-380	14.8	200-400	4	426	41	18	150	118	ER32-Ø3.175-Ø20	油脂 Grease	水冷 Cool	2X7009C P4 2X7007C P4	46
GDK150-6-12Z/5.5-11B	6000-12000	5.5	8.75-4.38	269-380	14.8	200-400	4	427	42	18	150	118	ER40-Ø3.175-Ø26	油脂 Grease	水冷 Cool	2X7010C P4 2X7007C P4	46

\*恒功率主轴后面的一个功率为峰值功率。

说明：产品和规格如有更新时，将不另行通知，请以实物为准。

**HQD**  
加工中心  
风冷自动换刀主轴

MACHINING CENTER  
AIR-COOLED  
AUTOMATIC TOOL  
CHANGE SPINDLE

6kw 换刀  
9kw 换刀  
12kw 换刀  
14kw 换刀

风冷却 油脂润滑

常州市高新技术产品认定证书

### 产品介绍

风冷自动换刀电主轴是我公司专门设计研发的一款高端大功率风扇冷却电主轴，轴承为德国进口高精度轴承，进口高速轴承油脂。采用二路气密封结构，使用HSK-F63刀柄或ISO30刀柄，实现快速自动换刀，提高加工效率。

### PRODUCTS

Air-cooled automatic tool change spindle is a high-end woodworking company designed to develop high-power electric spindle bearings imported from Germany, high-precision bearings, high precision, long life. The electric spindle fan cooling with Road gas seal structure, automatic tool changer with ISO30 shank, fast automatic tool change and improve the efficiency of the automated processing.

### 技术参数 TECHNICAL DATA

主轴型号 Spindle type	电机 Motor						外形尺寸 Dimensions (mm)						轴端连接 Joint of nose	润滑 Lub	冷却 Cool	轴承型号 Bearings type	重量 kg	
	转速 (r/min)	额定功率 KW	电压 V	电流 A	频率 Hz	极数 PI	L	L1	L2	L3	ØD	ØD1						ØD2
GDL51-24Z/4.5	12000-24000	4.5	380	9.0	400-800	4	477.5	49	67	195		64	90	ISO30 锥孔	油脂 Grease	风扇 Fan	2X7008C P4 2X7006C P4	17
GDL60-24Z/6.0	24000	6	380	12.5	800	4	531	62.5	80.5	235		64	90	ISO30 锥孔	油脂 Grease	风扇 Fan	2X7008C P4 2X7006C P4	21
GDL70-24Z/9.0 Long nose	12000-24000	9	380 220	20.0 32.0	400-800	4	551	113	126	221.5	133	64	110	ISO30 锥孔	油脂 Grease	风扇 Fan	2X7008C P4 2X7006C P4	30
GDL70-24Z/9.0 Short nose	12000-24000	9	380 220	20.0 32.0	400-800	4	471	33	46	221.5	133	64	100	ISO30 锥孔	油脂 Grease	风扇 Fan	2X7008C P4 2X7006C P4	25
GDL70-24Z/12	24000	12	380	20.0	800	4	554	106	119	221.5	133	63	110	HSK F63 刀柄	油脂 Grease	风扇 Fan	2X7009C P4 2X7006C P4	31
GDL71-24Z/14	24000	14	380	24.0	800	4	559.5	106.5	124.5	271.5	141	63	100	HSK F63 刀柄	油脂 Grease	风扇 Fan	2X7009C P4 2X7007C P4	32
GDL71-24Z/14	24000	14	380	24.0	800	4	559.5	106.5	124.5	271.5	141	63	100	ISO30 锥孔	油脂 Grease	风扇 Fan	2X7009C P4 2X7007C P4	32

**HQD**  
圆形  
风冷主轴

AIR-COOLED  
SPINDLE

常州市高新技术产品认定证书

圆形风冷 风冷却 油脂润滑

### 圆形风冷电主轴技术参数 TECHNICAL DATA (专利号 201010213738.8)

主轴型号 Spindle type	电机 Motor							外形尺寸 Dimensions (mm)					轴端连接 Joint of nose	润滑 Lub	冷却 Cool	轴承型号 Bearings type	重量 kg
	转速 (r/min)	额定功率 KW	扭矩 Nm	电压 V	电流 A	频率 Hz	极数 PI	L	L1	L2	ØD	ØD1					
GDF65-24Z/0.8	24000	0.8	0.22	220 380	3.0 1.6	400	2	245	21	15.5	65	50.5	ER11-Ø3.175-Ø7.0	油脂 Grease	风冷 Fan	2X7002C P4 2X7000C P4	3.0
GDF80-24Z/1.5	24000	1.5	0.38	220 380	5.6 3.0	400	2	238	20	8.5	80	67	ER11-Ø3.175-Ø7.0	油脂 Grease	风冷 Fan	2X7002C P4 2X7002C P4	4.0
GDF80-24Z/2.2	24000	2.2	0.58	220 380	7.6 4.4	400	2	263.5	21	19	80	58.5	ER16-Ø3.175-Ø10	油脂 Grease	风冷 Fan	1X7002C P4 2X7004C P4	4.5
GDF80-24Z/2.2B	24000	2.2	0.58	220 380	7.6 4.4	400	2	269.5	29.5	20	80	59.5	ER20-Ø3.175-Ø13	油脂 Grease	风冷 Fan	1X7002C P4 2X7005C P4	5.0

说明：产品和规格如有更新时，将不另行通知，请以实物为准。



# 方形 风冷主轴

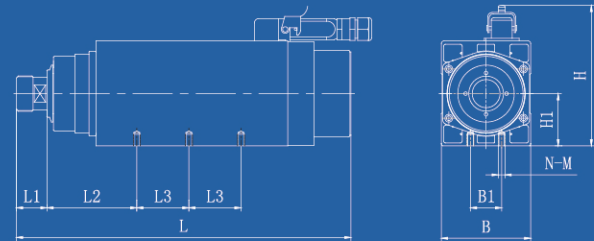
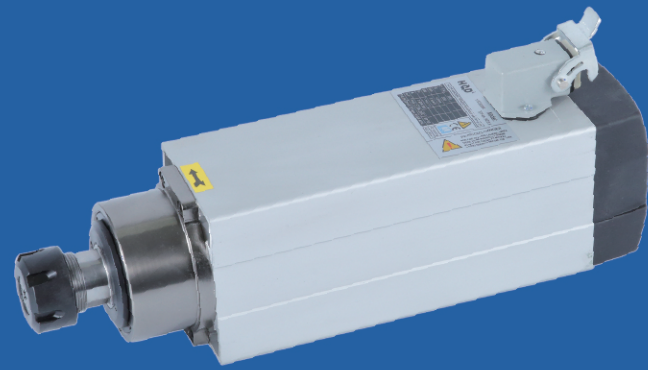

方形风冷电主轴示意图



# 风冷安装 座主轴

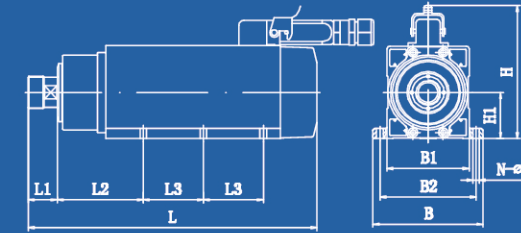

## 技术参数 TECHNICAL DATA

主轴型号 Spindle type	电机 Motor							外形尺寸 Dimensions(mm)										轴端连接 Joint of nose	润滑 Lub	冷却 Cool	轴承型号 Bearings type	重量 kg
	转速 (r/min)	额定 功率 KW	扭矩 Nm	电压 V	电流 A	频率 Hz	极数 PI	L	L1	L2	L3	B	B1	B2	H	H1	N-Ø					
GDF37-18Z/2.2	18000	2.2	1.17	380	4.3	300	2	256.5	25.5	67	35	110	80	95	104.3	37	8-Ø7	ER20-Ø3.175-Ø13	油脂 Grease	风冷 Fan	2X7005C P4 1X6002V P4	5
GDF46-18Z/1.5	18000	1.5	0.80	220	5.6	300	2	258.5	29	86	90	110	82	96	123.3	46	4-Ø6.5	ER20-Ø3.175-Ø13	油脂 Grease	风冷 Fan	2X7005C P4 1X6002V P5	6
GDF46-24Z/1.5	24000	1.5	0.60	380	3.0	400	2	258.5	29	86	90	110	82	96	123.3	46	4-Ø6.5	ER20-Ø3.175-Ø13	油脂 Grease	风冷 Fan	2X7005C P4 1X7002C P4	6
GDF46-18Z/2.2	18000	2.2	1.17	220	7.8	300	2	288.5	29	86	60	110	82	96	123.3	46	6-Ø6.5	ER20-Ø3.175-Ø13	油脂 Grease	风冷 Fan	2X7005C P4 1X6002V P5	7
GDF46-24Z/2.2	24000	2.2	0.88	380	4.4	400	2	288.5	29	86	60	110	82	96	123.3	46	6-Ø6.5	ER20-Ø3.175-Ø13	油脂 Grease	风冷 Fan	2X7005C P4 1X7002C P4	7
GDF46-18Z/2.2	18000	2.2	1.17	220	7.8	300	2	288.5	29	86	60	110	82	96	123.3	46	6-Ø6.5	ER25-Ø3.175-Ø16	油脂 Grease	风冷 Fan	2X7007C P4 2X7002C P4	7
GDF46-18Z/3.5	18000	3.5	1.59	220	12.0	300	2	328.5	29	86	60	110	82	96	123.3	46	6-Ø6.5	ER25-Ø3.175-Ø16	油脂 Grease	风冷 Fan	2X7007C P4 2X7002C P4	8.5
GDF46-24Z/3.5	24000	3.5	1.36	380	7.0	400	2	328.5	29	86	60	110	82	96	123.3	46	6-Ø6.5	ER20-Ø3.175-Ø13	油脂 Grease	风冷 Fan	2X7005C P4 1X7002C P4	8
GDF46-18Z/3.5	18000	3.5	1.59	220	12.0	300	2	328.5	29	86	60	110	82	96	123.3	46	6-Ø6.5	ER20-Ø3.175-Ø13	油脂 Grease	风冷 Fan	2X7005C P4 1X7002C P4	8
GDF46-24Z/3.5	24000	3.5	1.19	380	7.0	400	2	328.5	29	86	60	110	82	96	123.3	46	6-Ø6.5	ER20-Ø3.175-Ø13	油脂 Grease	风冷 Fan	2X7005C P4 1X6003C P4	8
GDF55-12Z/2.2	12000	2.2	1.75	220 380	7.1 4.1	200	2	354	68	48.5	190.5	126.5	55	138.5	55	4-M8	Ø30圆柱键-M16内螺纹	油脂 Grease	风冷 Fan	2X7007C P4 2X7004C P4	8	
GDF60-18Z/4.5	18000	4.5	2.39	220	15.0	300	2	330.5	37	93.5	60	103	36	157	60	6-M8	ER25-Ø3.175-Ø16	油脂 Grease	风冷 Fan	2X7007C P4 2X7002C P4	12	
GDF60-24Z/4.5	24000	4.5	1.79	380	9.0	400	2	330.5	37	93.5	60	103	36	157	60	6-M8	ER25-Ø3.175-Ø16	油脂 Grease	风冷 Fan	2X7007C P4 2X7002C P4	12	
GDF60-18Z/4.5	18000	4.5	2.39	220 380	15.0 9.0	300	2	330.5	35	95.5	60	103	36	157	60	6-M8	ER32-Ø3.175-Ø20	油脂 Grease	风冷 Fan	2X7008C P4 2X7002C P4	12	
GDF60-18Z/6.0	18000	6.0	3.18	220 380	21.0 12.0	300	2	350.5	35	95.5	60	103	36	157	60	6-M8	ER32-Ø3.175-Ø20	油脂 Grease	风冷 Fan	2X7008C P4 2X7002C P4	13	
GDF60-18Z/7.5	18000	7.5	3.98	220 380	26.0 15.0	300	2	393.5	35	95.5	60	103	36	157	60	8-M8	ER32-Ø3.175-Ø20	油脂 Grease	风冷 Fan	2X7008C P4 2X7003C P4	16	
GDF60-18Z/7.0	18000	7.0	3.71	220 380	24.0 14.0	600	4	358.5	35	103.5	60	103	36	157	60	6-M8	ER32-Ø3.175-Ø20	油脂 Grease	风冷 Fan	2X7008C P4 2X7003C P4	13	
GDF60-18Z/9.0	18000	9.0	4.78	220 380	31.5 19.0	600	4	419.5	35	121.5	60	103	36	157	60	8-M8	ER32-Ø3.175-Ø20	油脂 Grease	风冷 Fan	2X7008C P4 2X7004C P4	17	
GDZ-22	20000	0.8	0.18	220	4.0	333	2	207	27	44.5	40	80	22	95	41	6-M6	ER11-Ø3.175-Ø7.0	油脂 Grease	风冷 Fan	1X6003 NSK 1X6002 NSK	2.8	

## 方形风冷电主轴技术参数 TECHNICAL DATA

主轴型号 Spindle type	电机 Motor							外形尺寸 Dimensions(mm)										轴端连接 Joint of nose	润滑 Lub	冷却 Cool	轴承型号 Bearings type	重量 kg
	转速 (r/min)	额定 功率 KW	扭矩 Nm	电压 V	电流 A	频率 Hz	极数 PI	L	L1	L2	L3	B	B1	H	H1	N-M						
GDF46-18Z/1.5	18000	1.5	0.80	220 380	5.6 3.0	300	2	258.5	29	86	90	82	30	129	46	4-M6	ER20-Ø3.175-Ø13	油脂 Grease	风冷 Fan	2X7005C P4 1X6002V P4	6	
GDF46-24Z/1.5	24000	1.5	0.60	220 380	5.6 3.0	400	2	258.5	29	86	90	82	30	129	46	4-M6	ER20-Ø3.175-Ø13	油脂 Grease	风冷 Fan	2X7005C P4 1X7002C P4	6	
GDF46-18Z/2.2	18000	2.2	1.17	220	7.8	300	2	288.5	29	86	90	82	30	129	46	4-M6	ER20-Ø3.175-Ø13	油脂 Grease	风冷 Fan	2X7005C P4 1X7002C P4	7	
GDF46-24Z/2.2	24000	2.2	0.88	380	4.4	400	2	288.5	29	86	90	82	30	129	46	4-M6	ER20-Ø3.175-Ø13	油脂 Grease	风冷 Fan	2X7005C P4 1X7002C P4	7	
GDF46-18Z/3.5	18000	3.5	1.59	220	12.0	300	2	328.5	29	86	90	82	30	129	46	6-M6	ER25-Ø3.175-Ø16	油脂 Grease	风冷 Fan	2X7007C P4 2X7002C P4	8	
GDF46-24Z/3.5	24000	3.5	1.36	380	7.0	400	2	328.5	29	86	90	82	30	129	46	6-M6	ER25-Ø3.175-Ø16	油脂 Grease	风冷 Fan	2X7007C P4 2X7002C P4	8	
GDF55-12Z/2.2	12000	2.2	1.75	220 380	7.1 4.1	200	2	354	68	48.5	190.5	126.5	55	138.5	55	4-M8	Ø30圆柱键-M16内螺纹	油脂 Grease	风冷 Fan	2X7007C P4 2X7004C P4	8	
GDF60-18Z/4.5	18000	4.5	2.39	220	15.0	300	2	330.5	37	93.5	60	103	36	157	60	6-M8	ER25-Ø3.175-Ø16	油脂 Grease	风冷 Fan	2X7007C P4 2X7002C P4	12	
GDF60-24Z/4.5	24000	4.5	1.79	380	9.0	400	2	330.5	37	93.5	60	103	36	157	60	6-M8	ER25-Ø3.175-Ø16	油脂 Grease	风冷 Fan	2X7007C P4 2X7002C P4	12	
GDF60-18Z/4.5	18000	4.5	2.39	220 380	15.0 9.0	300	2	330.5	35	95.5	60	103	36	157	60	6-M8	ER32-Ø3.175-Ø20	油脂 Grease	风冷 Fan	2X7008C P4 2X7002C P4	12	
GDF60-18Z/6.0	18000	6.0	3.18	220 380	21.0 12.0	300	2	350.5	35	95.5	60	103	36	157	60	6-M8	ER32-Ø3.175-Ø20	油脂 Grease	风冷 Fan	2X7008C P4 2X7002C P4	13	
GDF60-18Z/7.5	18000	7.5	3.98	220 380	26.0 15.0	300	2	393.5	35	95.5	60	103	36	157	60	8-M8	ER32-Ø3.175-Ø20	油脂 Grease	风冷 Fan	2X7008C P4 2X7003C P4	16	
GDF60-18Z/7.0	18000	7.0	3.71	220 380	24.0 14.0	600	4	358.5	35	103.5	60	103	36	157	60	6-M8	ER32-Ø3.175-Ø20	油脂 Grease	风冷 Fan	2X7008C P4 2X7003C P4	13	
GDF60-18Z/9.0	18000	9.0	4.78	220 380	31.5 19.0	600	4	419.5	35	121.5	60	103	36	157	60	8-M8	ER32-Ø3.175-Ø20	油脂 Grease	风冷 Fan	2X7008C P4 2X7004C P4	17	
GDZ-22	20000	0.8	0.18	220	4.0	333	2	207	27	44.5	40	80	22	95	41	6-M6	ER11-Ø3.175-Ø7.0	油脂 Grease	风冷 Fan	1X6003 NSK 1X6002 NSK	2.8	



# 低噪音 风冷 电主轴

LOW NOISE  
AIR COOLING  
SPINDLE

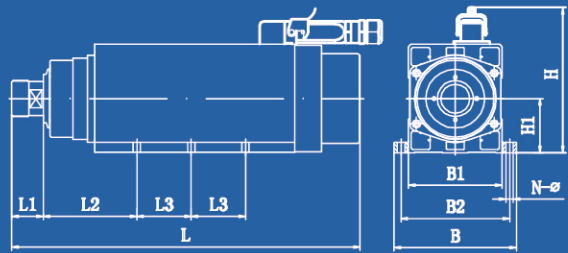
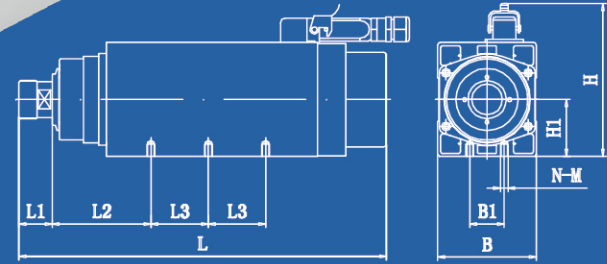
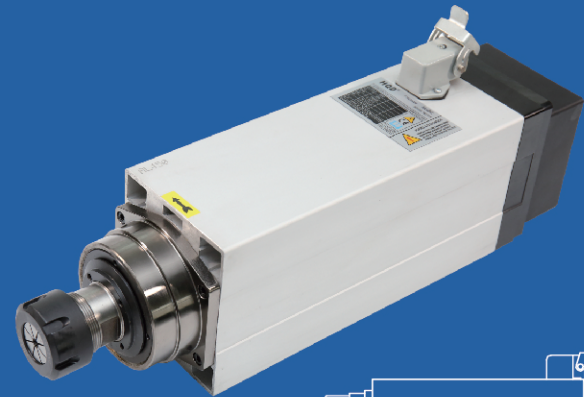

## 产品介绍

GDF 系列低噪音风冷电主轴是我公司开发的第一代独立风扇冷却的电主轴，它采用高速轴流风扇，具有低噪音、低温升、大功率的特点。

使用时风扇必须常开，可以满足用户对低噪音大功率风冷电主轴的需求。

## PRODUCTS

GDF series low noise air cooling spindle motor spindle is my company developed the first generation of independent cooling fan, it uses speed axialflow fan, has the characteristics of low noise.

low temperature rise, high power. when using the fan must be open, canmeet the needs of users of low-noise high-power air-cooled electric spindle.

## 技术参数 TECHNICAL DATA

主轴型号 Spindle type	电机 Motor							外形尺寸 Dimensions(mm)								轴端连接 Joint of nose	润滑 Lub	冷却 Cool	轴承型号 Bearings type	重量 kg		
	转速 (r/min)	额定 功率 KW	扭矩 Nm	电压 V	电流 A	频率 Hz	极数 PI	L	L1	L2	L3	B	B1	B2	H						H1	N-M
GDF60-18Z/5.5	18000	5.5	2.65	220 380	21.5 12.5	300	2	385	35	103.5	60	103	36	157	60	6-M8	ER32-Ø3.175-Ø20	油脂 Grease	风冷 Fan	2X7008C P4 2X7002C P4	13.5	
GDF70-24Z/9.0	24000	9.0	3.58	380	20.0	800	4	498	35.5			133	80	180	70.5		ER32-Ø3.175-Ø20	油脂 Grease	风冷 Fan	2X7008C P4 2X7006C P4	22	
GDF87-18Z/13.5	18000	13.5	6.36	380	31.0	600	4	553	38	148.0	135	145	70	214.5	87.5	6-M12	ER40-Ø3.175-Ø26	油脂 Grease	风冷 Fan	2X7010C P4 2X7007C P4	39	
GDF60-18Z/5.5	18000	5.5	2.65	220 380	21.5 12.5	300	2	385	35	103.5	60	135	103	120	157	60	6-Ø8.5	ER32-Ø3.175-Ø20	油脂 Grease	风冷 Fan	2X7008C P4 2X7002C P4	13



# 封边 风冷 电主轴

EDGE-  
SEALING  
AIR COOLING  
SPINDLE

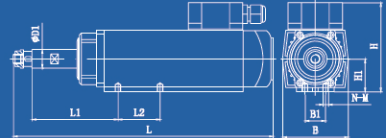
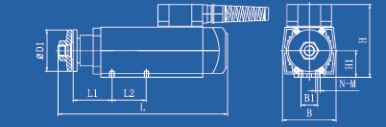
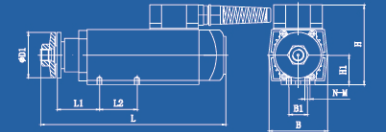

## 产品介绍

GDF系列封边风冷电主轴是我公司开发的木工封边专用风冷电主轴，它采用优化设计同轴风叶和风罩，具有低噪音、低温升、大扭矩的特点。可以满足用户对木工封边高强度高可靠性的需求！

## PRODUCTS

GDF serial edge-sealing air cooling electrical spindle is developed specially for the edge-banding of woodworking. It applies the co-axial eight-table fan which has the features of double-voltage, low noise, low temperature-rise and large torque. It fills the user's requirements of high strength and high reliability to the edge-banding of woodworking.

主轴型号 Spindle type	电机 Motor							外形尺寸 Dimensions(mm)								轴端连接 Joint of nose	润滑 Lub	冷却 Cool	轴承型号 Bearings type	重量 kg	
	转速 (r/min)	额定 功率 KW	扭矩 Nm	电压 V	电流 A	频率 Hz	极数 PI	L	L1	L2	ØD1	D	D1	H	H1						N-M
GDF35-12Z/0.37	12000	0.37	0.29	Y220	2.0	200	2	220.5	49	40	54.2	70	22	95	35	4-M6	Ø15 圆柱连接-M14 左牙	油脂 Grease	风冷 Fan	1X6003VV P4 1X6001VV P4	2.6
GDF35-12Z/0.37	12000	0.37	0.29	Y220	2.0	200	2	220.5	49	40	54.2	70	22	95	35	4-M6	Ø15 圆柱连接-M14 右牙	油脂 Grease	风冷 Fan	1X6003VV P4 1X6001VV P4	2.6
GDF35.5-18Z/0.3	18000	0.30	0.16	Y165	2.1	300	2	247	87	40	20	70	22	95	35	4-M6	Ø16 圆柱键 -M10*1.5左牙	油脂 Grease	风冷 Fan	1X6001VV P4 1X6005VV P4	2.5
GDF35.5-18Z/0.3	18000	0.30	0.16	Y165	2.1	300	2	247	87	40	20	70	22	95	35	4-M6	Ø16 圆柱键 -M10*1.5右牙	油脂 Grease	风冷 Fan	1X6001VV P4 1X6005VV P4	2.5
GDF35-18Z/0.75	18000	0.75	0.40	Y220	3.7	300	2	277	90	40	20	70	22	95	35	4-M6	Ø16 圆柱键 -M10*1.5左牙	油脂 Grease	风冷 Fan	1X6001VV P4 1X6005VV P4	3.0
GDF35-18Z/0.75	18000	0.75	0.40	Y220	3.7	300	2	277	90	40	20	70	22	95	35	4-M6	Ø16 圆柱键 -M10*1.5右牙	油脂 Grease	风冷 Fan	1X6001VV P4 1X6005VV P4	3.0
GDF35-12Z/1.1	12000	1.10	0.8	Y220	4.3	200	2	292	90	61	20	70	22	95	35	8-M6	Ø16 圆柱键 -M10*1.5左牙	油脂 Grease	风冷 Fan	1X6001VV P4 1X6005VV P4	3.3
GDF35-12Z/1.1	12000	1.10	0.8	Y220	4.3	200	2	292	90	61	20	70	22	95	35	8-M6	Ø16 圆柱键 -M10*1.5右牙	油脂 Grease	风冷 Fan	1X6001VV P4 1X6005VV P4	3.3
GDF35-12Z/1.1	12000	1.10	0.8	Y220	4.3	200	2	260.5	57	21	54.2	70	22	90.5	35	8-M6	Ø15 圆柱键 -M14 右牙	油脂 Grease	风冷 Fan	1X6005VV P4 1X6001VV P4	3.3
GDF35-12Z/1.1	12000	1.10	0.8	Y380	2.6	200	2	260.5	57	21	54.2	70	22	90.5	35	8-M6	Ø15 圆柱键 -M14 右牙	油脂 Grease	风冷 Fan	1X6005VV P4 1X6001VV P4	3.3
GDF71-12Z/9.0	12000	9.0	7.16	Y380 Δ 220	19 31	200	2	539.5	191	60	35	161	125	174.8	70.5	8-T型 螺母	Ø35 圆柱 -M30X2 左牙	油脂 Grease	风冷 Fan	2X7010C P4 1X6305VV P4	31
GDF71-12Z/9.0	12000	9.0	7.16	Y380 Δ 220	19 31	200	2	539.5	191	60	35	161	125	174.8	70.5	8-T型 螺母	Ø35 圆柱 -M30X2 右牙	油脂 Grease	风冷 Fan	2X7010C P4 1X6305VV P4	31
GDF71-4-8Z/5.5	4000- 8000	5.5	13.5- 6.75	Y380 Δ 220	12 21	200- 400	6	663	271.5	60	40	161	92	175	70.5	10- M10	Ø40 圆柱键 -M35X2 左牙	油脂 Grease	风冷 Fan	2X7011C P4 1X6206VV P4	39
GDF71-4-8Z/5.5	4000- 8000	5.5	13.5- 6.75	Y380 Δ 220	12 21	200- 400	6	663	271.5	60	40	161	92	175	70.5	10- M10	Ø40 圆柱键 -M35X2 右牙	油脂 Grease	风冷 Fan	2X7011C P4 1X6206VV P4	39



# 恒转矩电主轴

PERMANENT TORQUE SPINDLE

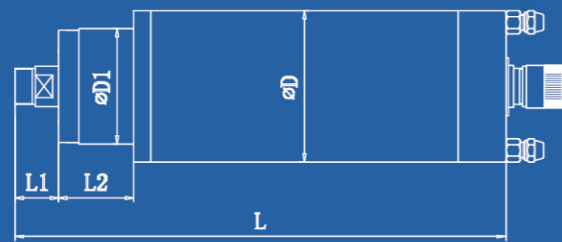

- 恒转矩
- 水冷却
- 自冷
- 油脂润滑

## 技术参数 TECHNICAL DATA

主轴型号 Spindle type	电机 Motor							外形尺寸 Dimensions(mm)					轴端连接 Joint of nose	润滑 Lub	冷却 Cool	轴承型号 Bearings type	重量 kg
	转速 (r/min)	额定功率 KW	扭矩 Nm	电压 V	电流 A	频率 Hz	极数 Pl	L	L1	L2	ØD	ØD1					
GDR58-24Z/0.4	24000	0.4	0.16	110	2.4	400	2	213	13.5	15.5	58	53.5	ER11-Ø3.175-Ø7.0	油脂 Grease	自冷 Self	1X7002C P4 1X7000C P4	3
GDK58-24Z/0.8	24000	0.8	0.32	220	3.0	400	2	219	13.5	15.5	58	53.5	ER11-Ø3.175-Ø7.0	油脂 Grease	水冷 Water	2X7002C P4 1X7000C P4	3
GDK80-24Z/1.5	24000	1.5	0.60	220 380	5.6 3.0	400	2	259	22	15	80	72	ER16-Ø3.175-Ø10	油脂 Grease	水冷 Water	2X7004C P4 2X7001C P4	7
GDK80-24Z/2.2	24000	2.2	0.80	220 380	7.6 4.4	400	2	284	26	15	80	78	ER20-Ø3.175-Ø13	油脂 Grease	水冷 Water	2X7005C P4 2X7002C P4	8
GDK80-40Z/4.0-4	40000	4	0.95	380	9.5	1333	4	275.5	25	13	80		ER20-Ø3.175-Ø13	油脂 Grease	水冷 Water	2X7005C P4 2X7004C P4	8
GDK85-24Z/2.2D	24000	2.2	0.88	220 380	7.6 5.5	400	2	284	27	15	85	69	ER20-Ø3.175-Ø13	油脂 Grease	水冷 Water	2X7005C P4 2X7203C P4	8
GDK85-24Z/2.2-BJ	24000	2.2	0.88	220 380	7.6 5.5	400	2	314	27	16	85	68.5	ER20-Ø3.175-Ø13	油脂 Grease	水冷 Water	2X7006C P4 2X7002C P4	10
GDK100-24Z/3.2	24000	3.2	1.27	220 380	11.0 6.4	400	2	295	26	32	100	78	ER20-Ø3.175-Ø13	油脂 Grease	水冷 Water	2X7005C P4 2X7003C P4	12
GDK105-21Z/3.5	21000	3.5	1.59	220 380	12.1 7.0	350	2	312	30	52	105	80	ER20-Ø3.175-Ø13	油脂 Grease	水冷 Water	2X7006C P4 2X7004C P4	15
GDK110-24Z/4.0	24000	4.0	1.59	220 380	14.0 8.0	400	2	352.5	30	62.5	110	85	ER25-Ø3.175-Ø16	油脂 Grease	水冷 Water	2X7007C P4 2X7004C P4	17
GDK110-18Z/4.0	18000	4.0	2.12	220 380	14.0 8.0	300	2	352.5	30	62.5	110	85	ER25-Ø3.175-Ø16	油脂 Grease	水冷 Water	2X7007C P4 2X7004C P4	17
GDK125-18-24Z/5.5	18000-24000	5.5	2.92 2.19	220 380	19.0 11.0	300-400	2	365	32.5	56	125	100	ER25-Ø3.175-Ø16	油脂 Grease	水冷 Water	2X7007C P4 2X7005C P4	23
GDK125-18Z/6.5	18000	6.5	3.45	220 380	22.5 13.0	300	2	372	33.5	62	125	100	ER32-Ø3.175-Ø20	油脂 Grease	水冷 Water	2X7008C P4 2X7005C P4	25
GDK125-24Z/6.5	24000	6.5	2.59	380	13	400	2	383	34.5	61	125	98	ER32-Ø3.175-Ø20	油脂 Grease	水冷 Water	2X7008C P4 2X7205C P4	25
GDK125-18Z/7.5	18000	7.5	3.98	220 380	28.0 16.0	900	6	395	29	59.5	125	100	ER25-Ø3.175-Ø16	油脂 Grease	水冷 Water	2X7007 C P4 2X7005C P4	31
GDK125-24Z/7.5	24000	7.5	2.98	220 380	28.0 15	800	4	404.5	36.5	44.5	125	92	ER32-Ø3.175-Ø20	油脂 Grease	水冷 Water	2X7008C P4 2X7006C P4	25.5
GDK125-15Z/11	15000	11	7.00	220 380	38.0 22.0	750	6	405	35	63.5	125	100	ER32-Ø3.175-Ø20	油脂 Grease	水冷 Water	2X7009C P4 2X7206C P4	24.5
GDK125-30Z/7.5	30000	7.5	2.38	380	15.0	1000	4	395.5	37.5	51	125	99	ER32-Ø3.175-Ø20	油脂 Grease	水冷 Water	2X7008C P4 2X7206C P4	31
GDK150-12Z/11	12000	11	8.75	380	22.0	400	4	426	41	18	150	118	ER32-Ø3.175-Ø20	油脂 Grease	水冷 Water	2X7209C P4 2X7007C P4	44
GDK150-12Z/11	12000	11	8.75	380	22.0	400	4	427	42	18	150	118	ER40-Ø3.175-Ø26	油脂 Grease	水冷 Water	2X7010C P4 2X7007C P4	45



# 钻床电主轴

钻床电主轴

DRILLING SPINDLE

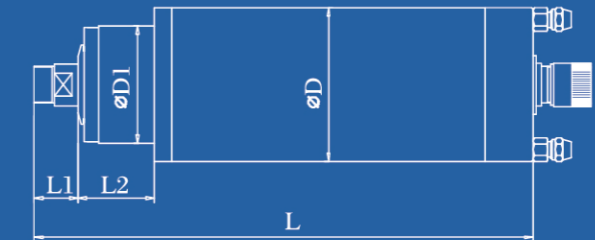

- 钻床
- 水冷却
- 油脂润滑

## 产品介绍

钻床主轴是我公司专门开发的钻孔电主轴，采用多级电机驱动，可以在800rpm - 2000rpm使用中3-中6刀对铜、钢、不锈钢等材质快速钻孔，孔深可达30mm。双层密封结构加气封结构，可以有效防止进液，保持电主轴长时间使用；NSK轴承和SKF油脂，确保性能优异。

## PRODUCTS

Drilling spindle is driven by multi-staged motor which enables the fast drilling on various materials like copper, steel and stainless steel with the speed of 800rpm - 2000rpm by the tools of Ø3 - Ø6. And the depth of drillhole can reach 30mm. Its double seal plus air seal structure can prevent effectively the liquid inlet which ensures the long-time service of the spindle.

## 技术参数 TECHNICAL DATA

主轴型号 Spindle type	电机 Motor						外形尺寸 Dimensions(mm)					轴端连接 Joint of nose	润滑 Lub	冷却 Cool	轴承型号 Bearings type	重量 kg
	转速 (r/min)	额定功率 KW	电压 V	电流 A	频率 Hz	极数 Pl	L	L1	L2	ØD	ØD1					
GDK80-12Z/2.2	1500-12000	2.2	220	6.4	50-400	4	284	26	15	80	78	ER20-Ø3.175-Ø13	油脂 Grease	水冷 Water	2X7005C P5 2X7002C P5	8
GDK105-9Z/3.0	1200-9000	3.0	220	9.6	20-150	2	344	29	55	105	80	ER20-Ø3.175-Ø13	油脂 Grease	水冷 Water	2X7006C P5 2X7004C P5	15.5
GDK105-18Z/4.5	1800-18000	4.5	380	9.6	30-300	2	344	29	55	105	80	ER20-Ø3.175-Ø13	油脂 Grease	水冷 Water	2X7006C P5 2X7004C P5	15.5
GDK125-9Z/5.5	1000-9000	5.5	220	19.5	50-450	6	405	35	63.5	125	100	ER32-Ø3.175-Ø20	油脂 Grease	水冷 Water	2X7009C P5 2X7005C P5	24.5
GDK125-9Z/5.5	1000-9000	5.5	380	11.0	50-450	6	405	35	63.5	125	100	ER32-Ø3.175-Ø20	油脂 Grease	水冷 Water	2X7009C P5 2X7005C P5	24.5

说明：产品和规格如有更新时，将不另行通知，请以实物为准。



### 产品介绍

GDZ系列双头电主轴是我公司专门开发的双头双向电主轴，可以在5000—24000rpm使用Φ3-Φ13刀对不同材质双向快速加工。它采用多层防护结构，可以保持电主轴使用寿命长。

ER20轴端为主要加工轴端，必须承担较大负荷。另一轴端为辅助加工轴端，必须承担较小负荷，这样工况下双头电主轴才耐用。

### PRODUCTS

GDZ double ends spindle is driven by secondary motor which enables the fast bi-directional processing on various materials with the speed of 5000rpm-24000rpm by the tools of  $\Phi 3 - \Phi 13$ . It applies multi-level protection to ensure the long-term service life of the spindle. The ER20 is the major processing end which shall bear the larger load, and the other end is the auxiliary processing end which shall bear the smaller load. In this case, the double ends spindle is durable!

### 技术参数 TECHNICAL DATA

主轴型号 Spindle type	电机 Motor		外形尺寸 Dimensions(mm)										轴端连接 Joint of nose	润滑 Lub	冷却 Cool	轴承型号 Bearings type	重量 kg		
	转速 (r/min)	额定功率 KW	电压 V	电流 A	频率 Hz	极数 P1	L	L1	L2	L3	L4	$\Phi D$						$\Phi D1$	$\Phi D2$
GDZ-30S	5000-24000	3	380 220	5.5 10	83-400	2	333	32.5	32	213	27	100	80	76	ER20- $\Phi 3.175-\Phi 13$ ER16 左- $\Phi 3.175-\Phi 10$	油脂 Grease	水冷 Water	2X7005C P4 2X7004C P4	10
GDZ-45S	5000-24000	4.5	380	9.0	83-400	2	378.5	29.5	33	253	29.5	100	80	77.5	ER20- $\Phi 3.175-\Phi 13$ ER20 左- $\Phi 3.175-\Phi 13$	油脂 Grease	水冷 Water	2X7005C P4 2X7005C P4	13.5
GDR120-12-18Z/5.5S	12000-18000	5.5	380	12.2	400-600	4	399	35.5	35.5	247	35.5	120	90	90	ER32- $\Phi 3.175-\Phi 13$ ER32- $\Phi 3.175-\Phi 13$ 左	油脂 Grease	水冷 Water	2X7008C P4 2X7008C P4	14.8

说明：产品和规格如有更新时，将不另行通知，请以实物为准。

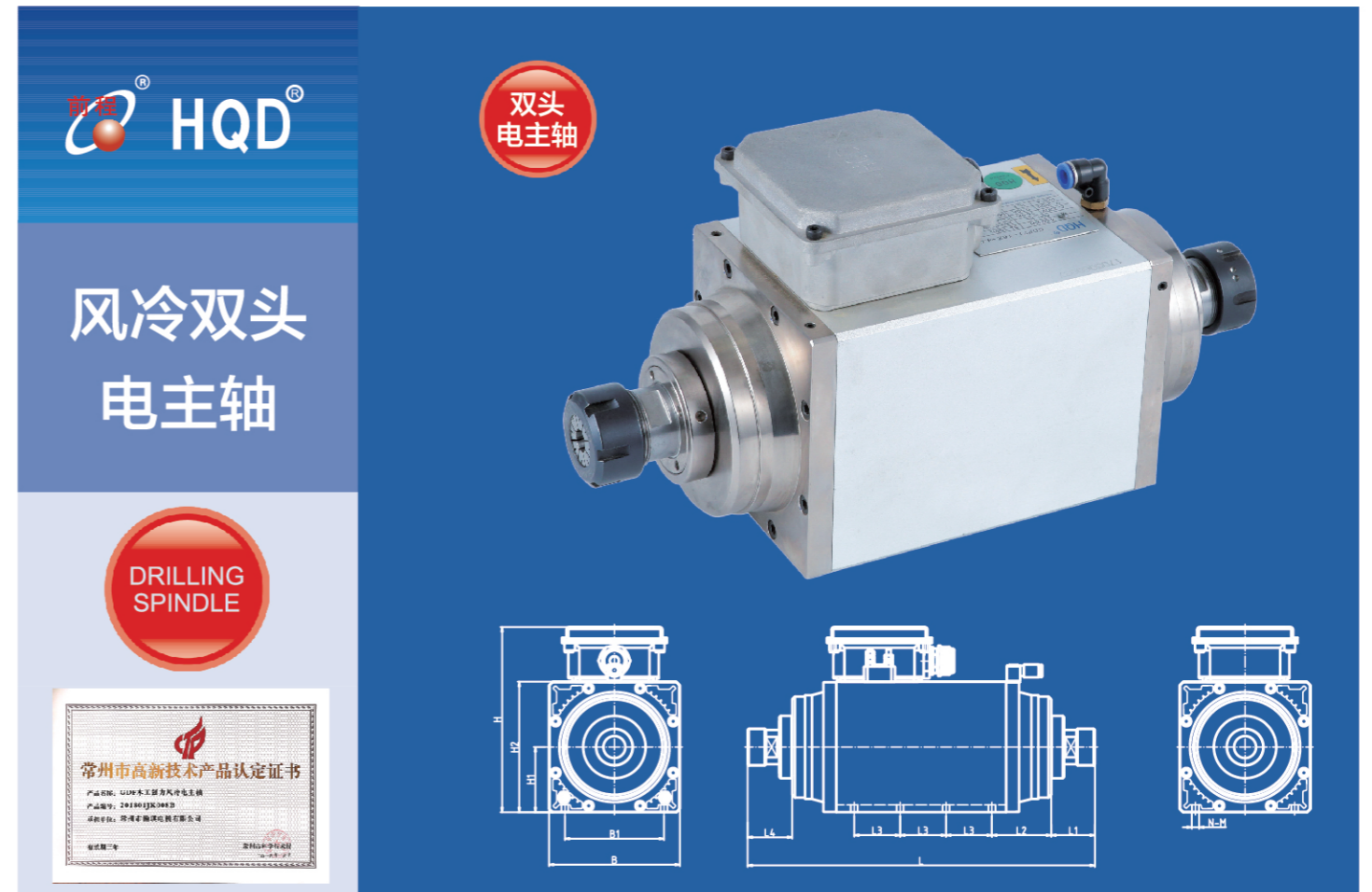

### 产品介绍

GDF双头电主轴是我公司专门开发的压缩空气冷却双头双向加工电主轴，它采用四级铜条转子电机驱动，可以在6000rpm-18000rpm使用03-020刀对不同材质双向快速加工。它采用多层防护结构，可以保持电主轴长寿命。ER32轴端为主要加工轴端，可以承担较大负荷。另一轴端必须承担较小负荷，这样工况下双头电主轴才耐用！压缩空气必须是清洁干燥的，过滤精度0.5微米。气压0.2-0.3MPa，压缩空气常开。建议使用两级过滤，过滤精度分别为0.5微米/0.5微米，并且空气过滤器带自排泄装置。

### PRODUCTS

GDF double ends spindle is a double ends and bi-directional spindle cooled by compressed air, driven by four-staged copper-bar rotor motor which enables the fast bi-directional processing on various materials with the speed of 6000rpm - 18000rpm by the tools of  $\Phi 3 - \Phi 20$ . The ER32 is the major processing end which shall bear the larger load, and the other end shall bear the smaller load. The compressed air shall be clean and dry with filtering precision of 0.5um and air pressure of 0.2 - 0.3MPa. The compressed air is normally open. It is suggested to apply two steps of filtering with the filtering precision of 5um and 0.5um respectively. And the air filter shall be equipped with self-discharging device.

### 技术参数 TECHNICAL DATA

主轴型号 Spindle type	电机 Motor		外形尺寸 Dimensions(mm)													轴端连接 Joint of nose	润滑 Lub	冷却 Cool	轴承型号 Bearings type	重量 kg		
	转速 (r/min)	额定功率 KW	电压 V	电流 A	频率 Hz	极数 P1	L	L1	L2	L3	L4	B	B1	H	H1						H2	N-M
GDR51-18Z/2.2S	18000	2.2	Y380 $\Delta 220$	6.0 10.4	300	2	251	28	53.5	88	28	120.6	55	102.5	51		4-M8	ER25- $\Phi 3.175-\Phi 16$	油脂 Grease	自冷	2X6206 P4	9.5
GDF60-18Z/3.5S	18000	3.5	380	7.80	300	2	393	48.0	73.5	50	48.0	135.0	120	160.5	60	120.0	8- $\Phi 8.5$	ER32- $\Phi 3.175-\Phi 20$ ER32左- $\Phi 3.175-\Phi 20$	油脂 Grease	风冷 Wind	2X7008C P4 2X7008C P4	16
GDF71-18Z/4.5S	18000	4.5	Y380 $\Delta 220$	9.50 16.4	600	4	378	47.5	64.5	50	48.5	142.5	108	201.75	71	142.25	8-M8	ER32- $\Phi 3.175-\Phi 20$ ER32左- $\Phi 3.175-\Phi 20$	油脂 Grease	风冷 Wind	2X7008C P4 2X7008C P4	27.5
GDF71-12Z/9.0S	12000	9.0	380	19.0	400	4	393	51.0	80	40	57.5	142.5	108	175.55	71	142.25	8-M8	$\Phi 25.4-M12$ 4-M6 ER40左- $\Phi 3.175-\Phi 26$	油脂 Grease	风冷 Wind	2X7010C P4 2X7010C P4	30

说明：产品和规格如有更新时，将不另行通知，请以实物为准。

广告木工  
用水冷  
电主轴

WOODWORKING WITH WATER-COOLED SPINDLE

常州市高新技术产品认定证书

锯片电主轴

WOODWORKING WITH WATER-COOLED SPINDLE

常州市高新技术产品认定证书

技术参数 TECHNICAL DATA

主轴型号 Spindle type	外形尺寸 Dimensions(mm)	电机 Motor						轴端连接 Joint of nose	冷却 Cool	润滑 Lub	相数 Number	轴承型号 Bearings type	重量 kg
		转速 (r/min)	额定功率 KW	电压 V	电流 A	频率 Hz	极数 PI						
GDZ-11	Ø48X120	10000-60000	0.09/0.1	36	0.6-1.5	160-1000	2	ER8Ø3.175-Ø5.0	自冷 Self	油脂 Grease	3	C136018JK C136100JK	1.4
GDZ-11-1	Ø42X176	10000-40000	0.07	36	1.6	167-667	2	ER8Ø3.175-Ø5.0	自冷 Self	油脂 Grease	3	C136018JK C136100JK	1.4
GDZ-12	Ø48X130	10000-60000	0.3	75	2.0-5.0	160-1000	2	ER8Ø3.175-Ø5.0	水冷 Water	油脂 Grease	3	C136101JK C136018JK	1.5
GDZ-13	Ø58X160	24000	0.8	75	6.5	400	2	ER11Ø3.175-Ø7.0	自冷 Self	油脂 Grease	3	7002C/P4X1 7000C/P4X1	2.5
GDZ-13-1	Ø58X192	24000	0.3/0.4	75	6.5	400	2	ER11Ø3.175-Ø7.0	水冷 Water	油脂 Grease	3	7002C/P4X1 7000C/P4X1	4.5
GDZ-15	Ø65X160	40000	0.8	220	3.5	667	2	ER11BØ3.175-Ø7.0	水冷 Water	油脂 Grease	3	7002C/P4X1 7000C/P4X1	4
GDZ-17	Ø80X180	24000	1.5	220	6	400	2	ER11Ø3.175-Ø7.0	水冷 Water	油脂 Grease	3	7002C/P4X1 7000C/P4X1	4
GDZ-17B	Ø80X225	24000	1.5	220 380	8 3.2	400	2	ER16Ø3.175-Ø10.0	水冷 Water	油脂 Grease	3	7004C/P4X2 7002C/P4X2	5
GDZ-18	Ø65X200	24000	1.5	220	5	400	2	ER11Ø3.175-Ø7.0	水冷 Water	油脂 Grease	3	7002C/P4X2 7001C/P4X1	4.5
GDZ-18B	Ø65X230	24000	1.5	220	5	400	2	ER16Ø3.175-Ø10.0	水冷 Water	油脂 Grease	3	7004C/P4X2 7001C/P4X2	4.5
GDZ18-2	Ø65X210	24000	0.8	220	5	400	2	ER11Ø3.175-Ø7.0	水冷 Water	油脂 Grease	3	7002C/P4X2 7000C/P4X2	4.5
GDZ-19	Ø80X190	24000	1.5	220	6	400	2	ER11Ø3.175-Ø7.0	水冷 Water	油脂 Grease	3	7002C/P4X2 1X7002C P4	5
GDZ-23	Ø80X235	24000	2.2	220/380	8.0/4.4	400	2	ER20Ø3.175-Ø13.0	水冷 Water	油脂 Grease	3	7005C/P4X2 7002C/P4X2	6
GDZ-23-1	Ø85X235	24000	2.2	220/380	8.0/4.4	400	2	ER20Ø3.175-Ø13.0	水冷 Water	油脂 Grease	3	7005C/P4X2 7002C/P4X2	7
GDZ-23-2	Ø80X225	24000	2.2	220/380	8.0/4.4	400	2	ER20Ø3.175-Ø13.0	水冷 Water	油脂 Grease	3	7005C/P4X2 7002C/P4X1	5
GDZ-24-1B	Ø100X265	24000	3.2	220/380	12/7	400	2	ER20Ø3.175-Ø13.0	水冷 Water	油脂 Grease	3	7005C/P4X2 7003C/P4X2	10
GDZ-24-1C	Ø100X278	24000	3.7	380	8	800	2	ER20Ø3.175-Ø13.0	水冷 Water	油脂 Grease	3	7005C/P4X2 7003C/P4X2	11.5
GDZ-24-2	Ø105X265	24000	3.2	220/380	12/7	400	2	ER20Ø3.175-Ø13.0	水冷 Water	油脂 Grease	3	7005C/P4X2 7003C/P4X2	11
GDZ-24-3	Ø100X250	24000	2.2	380/220	5/9	400	2	ER20Ø3.175-Ø13.0	水冷 Water	油脂 Grease	3	7005C/P4X2 7003C/P4X1	8.5
GDZ-26-1	Ø62X160	24000	0.8	220	3.5	400	2	ER11Ø3.175-Ø7.0	水冷 Water	油脂 Grease	3	7002C/P4X1 7000C/P4X1	2.5
GDZ-26	Ø62X210	24000/42000	0.8/1.2	220	5	400-700	2	ER11Ø3.175-Ø7.0	水冷 Water	油脂 Grease	3	7002C/P4X2 7000C/P4X2	4.5
GDZ-26-2	Ø62X210	60000	0.8/1.2	220	5	1000	2	ER11Ø3.175-Ø13.0	水冷 Water	油脂 Grease	3	7002C/P4X2 7000C/P4X2	4.5
GDZ-27	Ø100X300	24000	3.7/4.0/4.5	220/380	16/9	400	2	ER20Ø3.175-Ø13.0	水冷 Water	油脂 Grease	3	7005C/P4X2 7003C/P4X2	13

说明：产品和规格如有更新时，将不另行通知，请以实物为准。

技术参数 TECHNICAL DATA

主轴型号 Spindle type	电机 Motor						外形尺寸 Dimensions(mm)										轴端连接 Joint of nose	润滑 Lub	冷却 Cool	轴承型号 Bearings type	重量 kg
	转速 (r/min)	额定功率 KW	扭矩 Nm	电压 V	电流 A	频率 Hz	极数 PI	L	L1	L2	L3	B	B1	H	H1	N-M					
GDF35-12Z/0.75	12000	0.75	0.6	220 380	3.7 2.1	200	2	241	21	48	40/20	70	22	95	35	8-M6	Ø15圆柱键连接	油脂 Grease	风冷 Fan	1X6005 1X6001	3
GDF46-9Z/1.5	9000	1.5	17.5	220 380	6.24 3.6	150	2	334.5	25	66.5	25	81	44	123.8	40.5	20-M6	Ø30圆柱键连接	油脂 Grease	风冷 Fan	2X7007 VV P4 2X7002 VV P4	8.2
GDF46-12Z/1.5	12000	1.5	1.59	220 380	6.3 3.6	200	2	261	20	75	50	82	30	123.3	46	6-M6	Ø22带锯片法兰 M20*1.5左牙	油脂 Grease	风冷 Fan	2X7007 VV P4 2X7002 VV P4	4
GDF46-12Z/1.5	12000	1.5	1.59	220 380	6.3 3.6	200	2	261	20	75	50	82	30	123.3	46	6-M6	Ø22带锯片法兰 M20*1.5右牙	油脂 Grease	风冷 Fan	2X7007 VV P4 2X7002 VV P4	4
GDF71-3Z/4.5	3000	4.5	14.32	220 380	19.05 11.0	50	2	480	33	92	50	142	108	201	71	12-M8	Ø30带锯片法兰	油脂 Grease	风冷 Fan	2X6207 C3 1X6305 C3	25
GDF71-3Z/5.8	3000	5.8	17.5	220 380	19.05 11	50	2	553	38	92	50	142	108	201.2	71	14-M8	Ø30带锯片法兰	油脂 Grease	风冷 Fan	2X6207 C3 1X6305 C3	25
GDF71-3Z/5.8	3000	5.8	17.5	220 380	21.47 12.4	100	4	553	38	92	50	142	108	201.2	71	14-M8	Ø30带锯片法兰	油脂 Grease	风冷 Fan	2X6207 C3 1X6305 C3	25
GDF71-6Z/5.8	6000	5.8	9.23	220 380	21.47 12.4	200	4	423	31	92	80	142.5	108	199.5	71	6-M8	Ø30带锯片法兰	油脂 Grease	风冷 Fan	2X6207 C3 1X6305 C3	21
GDF71-6Z/7.5	6000	7.5	11.94	220 380	30.3 17.5	100	2	443.5	26			160	125	175.3	71	8-T型 螺母	Ø32圆柱键连接	油脂 Grease	风冷 Fan	2X6010 VV 1X6305 VV	31
GDF71-6Z/7.5	6000	7.5	11.94	220 380	30.3 17.5	100	2	443.5	54.5			160	125	174.8	70.5	8-T型 螺母	Ø30带锯片法兰	油脂 Grease	风冷 Fan	1X6306 VV 1X6305 VV	31

说明：产品和规格如有更新时，将不另行通知，请以实物为准。